

# **PROCESSING OF WOOD AND AGRICULTURAL BIOMASS FOR GASIFICATION**

by

**Pholoso Malatji**

*Thesis presented for the partial fulfillment degree of Master of  
Forestry*

at

*Stellenbosch University*

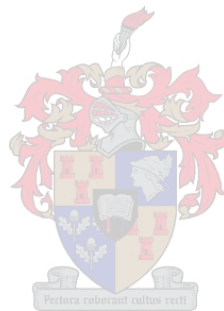

Department of Forest and Wood Science

Faculty of AgriScience

Promoter: Dr. Martina Meincken

Date: December 2009

---

## **DECLARATION**

By submitting this dissertation electronically, I declare that the entirety of the work contained therein is my own, original work, that I am the owner of the copyright thereof (unless to the extent explicitly otherwise stated) and that I have not previously in its entirety or in part submitted it for obtaining any qualification.

**Date: 19. November 2009**

## **ABSTRACT**

Wood waste, when used for gasification is commonly pressed into briquettes, especially if no uniform particle size is available. This densification reduces problems of handling, storage and transportation and improves the combustion performance because of a more uniform fuel size. Briquettes have to be mechanically strong enough to be handled. Cohesive strength is provided by residual moisture and lignin present in the wood. The lignin acts as a natural binder. However, the briquetting process becomes more complicated if one wants to add other agricultural waste products that do not necessarily contain lignin as binders,,

In this study we have investigated various briquetting process parameters, such as mixing ratios of briquettes containing wood chips, grape skins and chicken litter, moisture content and press time. The aim was to determine the optimum process parameters that allow the production of briquettes, containing a *blend* of biomaterials that are mechanically stable to allow further handling but yield high energy content at the same time.

**Keywords:** *Biomass, briquetting, blend, energy content*

## **OPSOMMING**

Wanneer houtafval vir vergassing gebruik word en die partikelgrootte daarvan varieer, word die materiaal normaalweg in 'n brikket gedruk. Brikketvorming vergemaklik opberging, hantering en vervoer. Weens die meer uniforme grootte en vorm van die brikkette is verbranding daarvan heelwat meer doeltreffend. Brikkette moet egter meganies sterk genoeg wees om hanteer te kan word. Die kohesiewe sterkte word deur residuele vog en lignien, wat as natuurlike bindmiddel in hout aanwesig is, verskaf. Indien ander materiale soos landbouafval, wat noodwendig geen lignien bevat nie egter gebruik word, word die brikketvormingsproses meer kompleks.

In hierdie ondersoek is verskeie brikketvormingsparameters evalueer. Mengverhoudings van brikkette wat houtspaanders, driuwedoppe en hoendermis bevat, asook invloed van materiaalvoggehalte en druktyd is bestudeer. Die doel was om die optimale materiaal- en prosesparameters vas te stel wanneer 'n mengsel van biomateriale gebruik word om brikkette te lewer wat meganies sterk genoeg is maar steeds die hoogste energieopbrengs lewer.

## **ACKNOWLEDGEMENTS**

I would like to express my sincere gratitude to:

- The Center for Renewable and Sustainable Energy Studies at the University of Stellenbosch for their continued financial support throughout the study.
- My supervisor, Dr. Martina Meincken for her selfless guidance, support, mentorship and valuable criticism in the research and write-up.
- Mr. Mark Februarie from the Department of Forest and Wood Science, Stellenbosch University for his technical support during sample collection.
- Dr. Jan Gertenbach in the Chemistry Department, Stellenbosch University for his experimental assistance during the study.
- Mr. Sampson Mamphweli and Sibusiso Mabizela from Fort Hare University Institute of Technology for their research and experimental assistance.
- The management and staff of Fort Hare University Institute of Technology for letting me conduct the study in their institute.
- My colleagues in the Department of Forest and Wood Science, Stellenbosch University.
- My parents Mr. Herman and Mrs. Matsie Malatji for their continued support and encouragement throughout this study.
- Ms. Bridgette Mthebule for her assistance in formatting and structuring this piece of work.

# Table of Contents

## Contents

DECLARATION .....	2
ABSTRACT .....	3
OPSOMMING .....	4
ACKNOWLEDGEMENTS .....	5
LIST OF TABLES .....	8
LIST OF FIGURES .....	9
1. OBJECTIVE .....	10
2. MOTIVATION .....	10
3. INTRODUCTION .....	11
3.1 Advantages and disadvantages of biomass as a fuel .....	12
3.2 Properties of Biomass .....	15
3.2.1 Cellulose .....	18
3.2.2 Lignin .....	19
3.2.3 Hemicelluloses .....	19
3.3 Thermal degradation of biomass components .....	21
4. BIOMASS PROCESSING .....	21
4.1 Preparation of wood and agricultural residues for densification .....	21
4.2 Briquetting and pelleting .....	22
4.3 Properties of Briquettes and Pellets .....	24
5. BIOMASS GASIFICATION .....	25
5.1 Gasification reactions .....	26
5.2 Types of gasification reactors .....	27
5.2.1 Updraft or counter current gasifier .....	28
5.2.2 Downdraft or Co-Current Moving Bed gasifiers .....	29
5.2.3 Fluidized bed gasifier .....	30
6. EXPERIMENTAL SETUP .....	32
6.1 Biomass Collection and Preparation .....	32
6.2 Laboratory Press .....	33
6.3 Stability and Density .....	33
6.4 Biomass .....	34
6.4.1 Wood .....	34
6.4.2 Grape skins .....	35
6.4.3 Chicken litter .....	37
6.5 Physical Properties of Briquettes .....	39
6.5.1 Ash Content .....	39
6.5.2 Energy Content .....	39
6.5.3 Thermogravimetric analysis (TGA) .....	40
6.5.4 Elemental Analysis .....	40
7. GASIFICATION AND SIMULATION OF EXPECTED PERFORMANCE .....	41
7.1 Gasification Reactor .....	41
7.2 Reaction Simulation .....	42
7.2.1 Chen's simulation model .....	42
8. RESULTS AND DISCUSSION .....	45
8.1 Press Settings .....	45
8.2 Thermal degradation .....	48
8.3 Elemental composition of briquettes .....	50
8.4 Gasification .....	51
8.5 Comparison pine wood and briquettes gasification .....	53
8.6 Gasification of briquettes .....	54

9.	CONCLUSIONS.....	55
10.	OUTLOOK.....	56
11.	REFERENCES .....	57

## LIST OF TABLES

TABLE 1: BIOMASS COMPOSITION AND CHEMICAL PROPERTIES.....	15
TABLE 2: ANALYSIS OF TYPICAL BIOMASS (WOOD) .....	16
TABLE 3: ASH COMPONENTS IN VARIOUS BIOMASSES AS WT% OF TOTAL ASH CONTENT.....	17
TABLE 4: THE TECHNICAL FEATURES OF BRIQUETTING AND PELLET MACHINES.....	24
TABLE 5: FUEL ANALYSES AND CHARACTERIZATION .....	35
TABLE 6: PROPERTIES OF GRAPE RESIDUE FEEDSTOCK.....	36
TABLE 7: PROPERTIES OF CHICKEN LITTER .....	38
TABLE 8: COMPARATIVE RESULTS OF CHEN'S MODEL WITH GRAHAM AND HUFFMAN.....	43
TABLE 9: EXPERIMENTALLY DETERMINED PARAMETERS OF BRIQUETTES AND PINE WOOD WITH GASIFIER OPERATING CONDITIONS ....	44
TABLE 10: DENSITY RATINGS OBTAINED FOR DIFFERENT PRESS SETTINGS AND DIFFERENT RAW MATERIALS.....	46
TABLE 11: ASH CONTENT AND CALORIFIC VALUE OF WOOD, GRAPE SKINS AND CHICKEN LITTER.....	47
TABLE 12: ASH CONTENT AND CALORIFIC VALUE OF BRIQUETTES CONTAINING A BLEND OF ALL THREE COMPONENTS.....	47
TABLE 13: DIFFERENT PEAK TEMPERATURES FROM THE DTG CURVES .....	49
TABLE 14: PERCENTAGE ELEMENTAL COMPOSITION.....	50



# LIST OF FIGURES

FIGURE 1: STRUCTURE OF CELLULOSE.....	18
FIGURE 2: THE STRUCTURE OF LIGNIN (ADLER, 1977) .....	19
FIGURE 3: MODEL STRUCTURES OF HEMICELULOSES (FENGEL & WEGENER, 1984).....	20
FIGURE 4: A TYPICAL BRIQUETTE PISTON PRESS .....	23
FIGURE 5: UPDRAFT OR COUNTER CURRENT GASIFIER. GAS LEAVES AT THE TOP AND OXIDANT INTAKE OCCURS THROUGH THE BOTTOM .....	29
FIGURE 6: DOWNDRAFT OR CO-CURRENT GASIFIER. GAS LEAVES THE REACTOR AT THE BOTTOM .....	30
FIGURE 7: FLUIDIZED BED GASIFIER .....	31
FIGURE 8: LABORATORY BRIQUETTES PRESS .....	33
FIGURE 9: LAB PRESSED WOOD BRIQUETTES .....	34
FIGURE 10: A) GRAPE RESIDUE AND B) GRAPE SKIN BRIQUETTES.....	37
FIGURE 11: CHICKEN LITTER A) AND B) CHICKEN LITTER BRIQUETTES.....	38
FIGURE 12: CAL2K-ECO BOMB CALORIMETER .....	39
FIGURE 13: Q-500 THERMOGRAVIMETRIC ANALYZER.....	40
FIGURE 14: PROTOTYPE DOWNDRAFT GASIFIER (OPEN).....	42
FIGURE 15: A) STABLE AND B) UNSTABLE BRIQUETTES.....	45
FIGURE 16: A) TGA CURVES AND B) DTG CURVES OF VARIOUS BRIQUETTES .....	48
FIGURE 17: PRODUCER GAS YIELD OF BRIQUETTES.....	51
FIGURE 18: HEATING VALUE OF THE PRODUCER GAS OBTAINED FROM BRIQUETTES .....	52
FIGURE 19: CONVERSION EFFICIENCY OF BRIQUETTES.....	52
FIGURE 20: PRODUCER GAS YIELD OF PINE WOOD .....	53
FIGURE 21: HEATING VALUE OF THE PRODUCER GAS OBTAINED FROM PINE WOOD .....	54

## **1. OBJECTIVE**

The objective of biomass pelleting or briquetting is to transform the material into suitably sized fuel for a specific conversion process such as gasification by reducing its moisture content and pressing it into uniformly sized, dense particles. Forest and agricultural biomass is often bulky and consists of particles with various sizes, which are difficult to handle. Densification into a uniform size enhances storage, transport and handling properties of the material, as well as improving the bulk density and energy content of biomass. The stability of the resulting briquettes depends, however, strongly on the chemical composition of the compressed material, i.e. the presence of lignin, which acts as a natural binder.

This project determined the processability of wood waste of pine and eucalyptus origin blended with two agricultural residues (grape skins and chicken litter) into briquettes intended for gasification. It is critical to determine the optimum moisture content (MC) and the ratio, in which the different materials can be blended to obtain mechanically stable briquettes without having to add binders.

## **2. MOTIVATION**

The consumption of fossil fuel resources is constantly mounting up and interest has started to shift towards biomass resources. Agricultural and forest residues can be processed into briquettes and used as biofuel. However, the chemical and physical characteristics of these materials, such as moisture, density, and size heterogeneity limit their efficiency when combusted.

These materials also have different combustion, physical and chemical characteristics that affect combustion. Blends of biomass materials could, on the other hand, offer the following benefits:

- A solution to the problem of waste disposal
- Form a substitute for fuel wood
- Add to the limited resources of wood waste

- Possibly increase the net calorific value per unit volume of biomass

In this project we determined the feasibility of compressing wood waste, grape skins and chicken litter into briquettes used for gasification. The optimum press settings - with regards to press time and moisture content - for the utilized laboratory press were determined for the three individual components, as well as blends with different mixing ratios. These briquettes were then tested for their physical properties, such as calorific value and ash content and their elemental composition. Briquettes made from the optimum ratio of all three components were tested in a laboratory gasifier for their performance.

### **3. INTRODUCTION**

Wood and agricultural residues are major choices as feedstock for energy production and they can either be used directly as fuel or thermo-chemically converted. Most of these biomass materials are, however, not suitable for direct utilization, because they are bulky, heterogeneous in size and shape and might differ in density. These differences not only make it difficult to handle, transport and store the biomass, but also to combust it, as most gasifiers cannot handle heterogeneous particle sizes.

There are numerous ways to resolve these problems, of which briquetting and/or pelleting are the most commonly utilized technologies (Kaliyan and Morey, 2009). This entails condensing the previously comminuted biomass into densified particles of uniform size, shape and density. Briquettes are typically larger than pellets with a diameter of about 8cm and a length of about 10 – 20 cm. Pellets have dimensions of only a few cm and less. This pre-processing of biomass into briquettes improves the handling characteristics, as well as the bulk density and ultimately the volumetric calorific value (Wilaipon, 2008). According to Shaw (2008), an advantage of the densification of loose, small and high moisture content biomass is that the compression generally increases the calorific value of the fuel. The bulk density of loose biomass, which is typically about 40 - 200 kg/m<sup>3</sup> can be increased to densities as high as 600 – 800 kg/m<sup>3</sup>.

Chemical composition, moisture content and final briquette density are the most important parameters affecting the combustion efficiency of any type of biomass.

Biomass can be derived from various resources, which differ in their chemical composition. Walker (2006) described lignin as the structural component of wood that acts as a natural adhesive and its amount varies for different species. Lignin facilitates the compression of small particles into briquettes, as it facilitates the adhesion between particles. Biomass other than wood, such as agricultural waste or chicken litter may contain less or no lignin and will therefore be less easy to compress into mechanically stable briquettes

Moisture affects the combustion efficiency negatively (Demirbas, 2004) and the moisture content should typically be as low as possible. On the other hand a certain amount of moisture is necessary to press briquettes and make sure that the biomass particles adhere to each other via hydrogen bonds. If the briquettes are pressed too dry, they will disintegrate which leads to biomass loss and makes it difficult to handle the briquettes.

Agricultural residues typically have high moisture content and calorific values different from wood (White and McGrew, 1976). The moisture content of chipped wood that has been air dried for several weeks varies between 10 and 20%, whereas agricultural biomass contains between 50% and 85% moisture (Hagström, 2006) depending on the type of feedstock. A moisture content of about 12% is acceptable in biomass fuels used for combustion, which means that most biomass has to be dried before it can be processed.

Typical energy contents range from 0.5 to 17 MJ/kg at 10-15% moisture content, depending on the type biomass feedstock (Maciejewska *et al.*, 2006).

An additional consideration with regards to the biomass fuel choice is the ash content. This is the inorganic matter that cannot be combusted and will remain in the form of ash and has to be discarded after combustion. Wood fuels typically have low ash contents around 0.5%, whereas many other agricultural residues can have ash contents as high as 20% or even more. The amount of inorganic matter in biomass also affects its ultimate calorific value (Strehler, 2000).

### **3.1 Advantages and disadvantages of biomass as a fuel**

Climate change and related global environmental conditions and changes in the atmospheric concentration of sulphur and carbon compounds are leading to an expanding interest towards alternatives to fossil fuels. Fossil fuel stocks are limited and have detrimental effects to the

environmental conditions, due to pollution caused by the emission of green house and other toxic gases. These waste gases contribute to climate change because they cause the following problems:

- Increased extremes in climatic conditions
- Increase in global temperature
- Loss of biodiversity
- Increased desertification
- Changes in sea water level

In this context, biomass could be used as an alternative energy resource, because it is composed of environmentally friendly, renewable compounds (Bezzon and Cortez, 1999; Strehler, 1998).

The definition of biomass encompasses numerous materials that may be converted into efficient fuels. These materials can be divided into the following:

- Woody biomass (wood, branches, leaves and wastes)
- Agricultural biomass and residues
- Industrial processing residues
- Dedicated energy crops
- Animal wastes (manure, poultry litter)

In this context, biomass is defined as all renewable organic material, whether in the form of plant materials, animal manure, food processing, forest materials or urban wastes (Scane, 1993; Kitani and Hall 1989).

According to Sonnenburg and Graef (1998), lignocellulosic organisms can be planted and harvested for the direct supply of bioenergy through incineration or for conversion to supply gaseous fuels or liquid fuels.

Biomass has drawn world-wide interest as a renewable energy resource because it does not negatively affect the environment (Coll *et al.*, 1998). From the previous decades, the use of biomass as an energy substitute to fossil fuels has been extensively explored. The most important advantage of biomass use for energy over fossil energy is its reduction in the amount of green house gases emissions such as carbon dioxide. This is because biomass is capable of re-sequestering the amount of carbon dioxide that is released when combusting it in the subsequent generation of plants (Gemtos and Tsiricoglou, 1999). Trees are potential carbon dioxide absorbers, which in turn is a major cause for global warming.

Biomass also compares well to its renewable resources counterparts, such as solar and wind energy, because it is widely available, easy to store, relatively cheap, and has a high energy efficiency potential (BMFT, 1986; Brokeland and Groot, 1995; Scholz and Berg, 1998).

According to a report by Franco *et al.*, (1998), biomass emits a very low amount of nitrogen- and sulphur containing polluting gases as opposed to fossil fuels such as coal and oil.

The composition of biomass fuels includes cellulose and hemicelluloses as opposed to aromatic components in coal, because they are highly oxygenated (Hall and Overend, 1987). Compared to fossil fuels, biomass contains more oxygen and less carbon, which leads to a lower calorific value per unit of biomass. This implies that in order to obtain an equivalent amount of fuel from biomass, more material needs to be processed (Unger, 1994).

The energy content of biomass is dictated by the amount of carbon and hydrogen. The theoretical energy content of most fully dried biomass is between 15-20 MJ/kg. The energy content decreases with increasing moisture content.

The disadvantages associated with biomass as a fuel according to White and Plaskett (1981) includes: (i) its low calorific value compared to fossils; (ii) the high moisture content, which inhibits the immediate combustion, because of dehydration requirements; (iii) low density and (iv) heterogeneous size, weight and shape.

Biomass composition is variable depending on the source plant, but the main components are cellulose, hemicelluloses and lignin and other components often grouped under the name extractives. It also contains a fraction of inorganic elements such as potassium or chlorine and foreign objects such as silica, soil, paper, and other unrelated impurities. In general, the inorganic components of biomass are responsible for the ash content of the fuel.

### 3.2 Properties of Biomass

It is important to understand the elemental composition of biomass in order to estimate its energy output or its performance in a conversion process. The composition and properties of different types of biomass, as well as some fossil fuels are indicated in Table 1.

*Table 1: Biomass composition and chemical properties*

Fuel	Volatile matter (%)	Calorific value (MJ/kg)	Ash (%)	C (%)	O (%)	H (%)	N (%)	S (%)
Straw	80.3	14.2	4.3	44.0	35.0	5.0	0.5	0.1
Wood	85.0	15.3	0.5	43.0	37.0	5.0	0.1	-
Charcoal	23.0	30.1	0.7	71.0	11.0	3.0	0.1	-
Peat	70.0	13.5	1.8	47.0	32.0	5.0	0.8	0.3
Brown coal	57.0	13.6	1-15	58.0	18.0	5.0	1.4	1.0
Mineral coal	26.0	29.5	1-15	73.0	5.0	4.0	1.4	1.0

*Source: Strehler, 1984.*

Wood has the lowest ash content of various biomass types, but compared with other carbon-based fuels also fairly low energy content. The chemical composition of biomass, especially the carbon content, determines the energy and ash content and its ultimate use.

Wood and other biomass feedstocks have different combustion characteristics that are basically dependent on their moisture content and chemical characteristics. It is a necessity to dry the biomass either in a kiln or in air, in order to increase its energy content. Rain protected and well aerated systems should be used to store biomass, particularly wood and straw (Strehler, 1984). Typical proximate and ultimate analysis data specifically for wood are given in Table 2.

**Table 2: Analysis of typical biomass (wood)**

<b>Proximate Analysis</b>	
Volatile matter, wt%	>70
Ash, wt%	1.5
Moisture, wt%	20
Fixed carbon, wt%	-
<b>Ultimate analysis</b>	
C, wt%	55
H, wt%	6.0
O, wt%	39
N, wt%	0.3
S, v	0.1

*Source: Higman and van der Burgt, 2003*

Combustion of biomass involves complex dynamic phenomena where simultaneous mass and heat transfer occur in various chemical reactions. Unlike similar biochemical and thermochemical conversion processes, combustion essentially reduces the entire biomass into simple products. Biomass fuels, such as wood or rice straw are composed of around 15 major elements that play an important role during the combustion process.

These elements are generally included in the empirical reaction formula of the biomass during combustion and they include carbon, hydrogen, oxygen, nitrogen, sulphur, chlorine, potassium, silicon, calcium, phosphorus and sodium. Inorganic are highly influential on the combustion process due to their ash formation. In biomass, carbon is the chief constituent accounting for 30% to 60% of the total dry matter. The typical oxygen content of biomass is about 30 to 40% and the hydrogen content is around 5 to 6%. The amount of nitrogen, sulphur and chlorine is highly variable in biomass at quantities less than 1% of the dry matter, but this can be higher in some cases. Sulphur and chlorine are important constituents of



polluting emissions, but they also lead to slagging and fouling reactions in the gasifier. In grasses and straws, silica is the third major constituent – up to 10 to 15% of dry matter.

Biomass fuels contain more oxygen and less carbon when compared to fossil fuels, which leads to a lower heating value (Demirbas, 2004).

The major combustion products of biomass are carbon, carbon monoxide, hydrogen and ash. Inorganic elements in biomass can react into variable products, such as alkali chlorides, carbonates, silicates and sulphates that cause fouling and slagging during further conversion (Jenkins *et al.*, 1998).

**Moisture content:** the amount of water present in the biomass, expressed as a percentage of the feedstock weight. Forest and agricultural biomass exhibit a wide range of moisture contents, which obviously affects the value of biomass as a fuel source. Excessive moisture in biofuels causes performance problems during combustion (Raveendran *et al.*, 1996).

**Ash content:** Agricultural biomasses, such as straw, groundnut shells and chicken litter often have high ash contents in the range of 4 to 10 wt%. The primary difference between the ash composition of biomass and fossil fuels is that biomass ash mainly consists of elements, such as potassium, calcium, sulphur, sodium, iron, silicon and other trace elements. Table 3 gives some examples of the ash component in various biomass types. The waste material left after the biomass has been combusted in an application is known as slag. Slagging results from a certain amount of ash and critical inorganic elements and could potentially result in ash-related problems in the gasification units. Slagging of biomass ash during gasification is therefore a major problem (Higman and van der Burgt, 2003).

**Table 3: Ash components in various biomasses as wt% of total ash content**

	<b>Straw</b>	<b>Miscanthus grass</b>	<b>Wood</b>
CaO	6.5	7.5	37.3
MgO	3.0	2.5	8.5
Na <sub>2</sub> O	1.3	0.2	3.0
K <sub>2</sub> O	23.7	12.8	8.6
<i>Source: Klensch, 2001</i>			

The variable composition of biomass fuels and variable moisture and ash contents could cause combustion and ignition problems. There are numerous ways of addressing these problems, such as blending different biomass fuels, which could enhance flame stability, as well as decrease corrosion effects.

### 3.2.1. Cellulose

Cellulose is the main component of the secondary cell wall in wood, where it forms long, crystalline microfibrils, which are nearly parallel to the fiber axis, causing most of the anisotropic conduct of wood materials. Cellulose is formed from a long chain of glucose monomer units, with the chemical structure  $C_6H_{12}O_6$ . A simplified structure of cellulose is given in Figure 1:

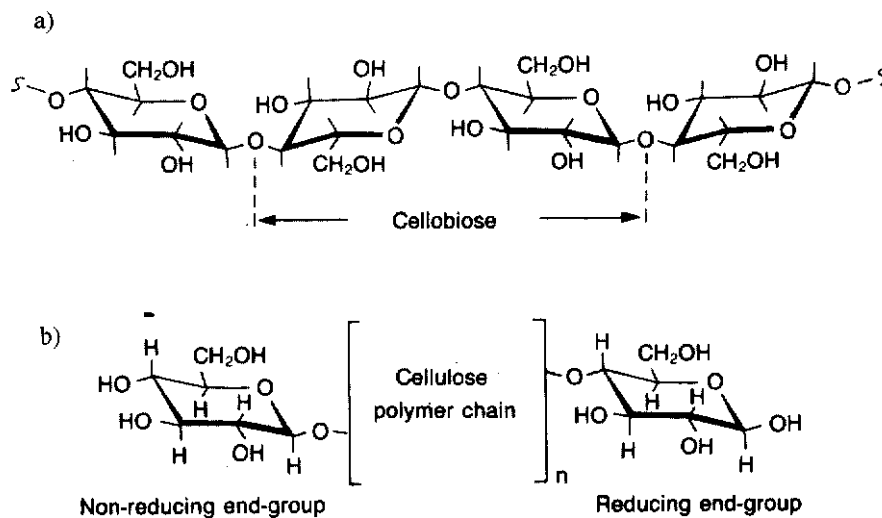

Figure 1: Structure of cellulose

Bossel (1980) reported that cellulose has a net calorific value of approximately 17.52 MJ/kg.

### 3.2.2. Lignin

Plaskett and White (1981) described lignin as the second largest structural component of biomass after cellulose, which is based upon benzene rings located on phenylpropane subunits. Lignin is the adhesive and aromatic component of wood, which is highly insolvent. Lignin differs amongst softwoods and hardwoods. Softwood lignin mostly contains guaiacyl units, whereas hardwood lignin consists of guaiacyl and syringyl units. Generally, softwood lignin has a higher molecular weight than hardwood lignin and softwoods contain about 25-35% lignin and hardwoods contain 18-25%. White and Plaskett (1981) further reported that lignin has an energy content of 25.5 MJ/kg, which is considerably higher than that of cellulose. Figure 2 represents the lignin structure in softwood.

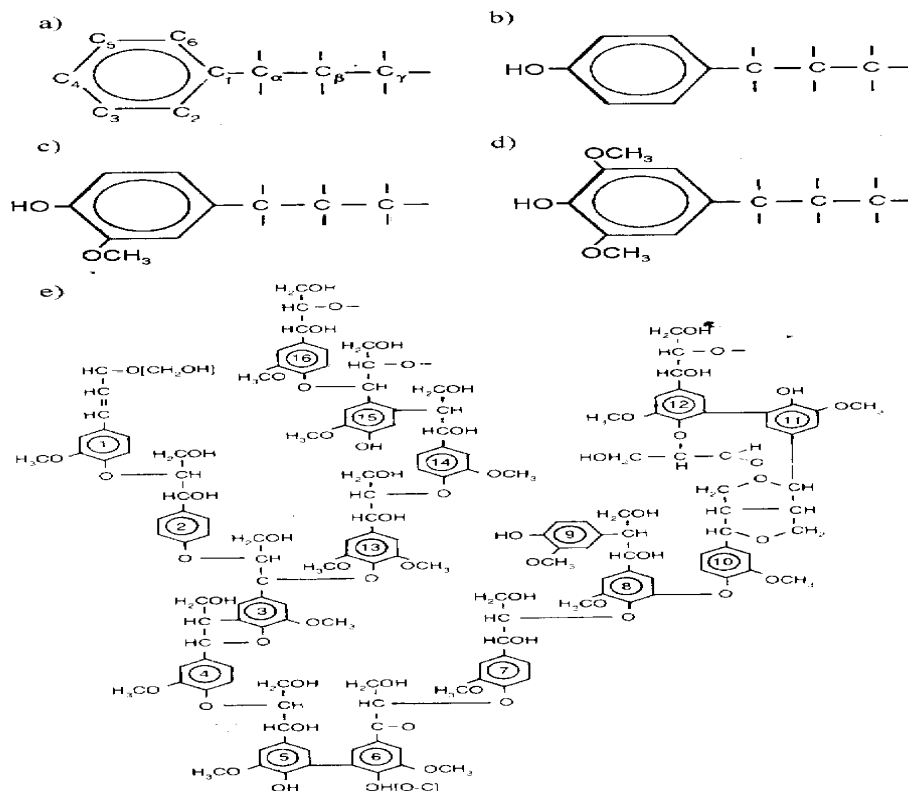

Figure 2: The structure of lignin (Adler, 1977)

### 3.2.3. Hemicelluloses

Most woody plants contain around 25 wt% hemicelluloses. Hemicelluloses and cellulose have similar chemical properties, except that hemicelluloses do not form a crystalline polymer. The monomer unit of hemicelluloses is smaller and they do not recur consistently as

in cellulose. The primary sugars found in hemicelluloses are pentose sugars (five-carbon sugars) D-xylose, L-arabino and hexose sugars (D-glucose, D-mannose and D-galactose) are represented in Figure 3.

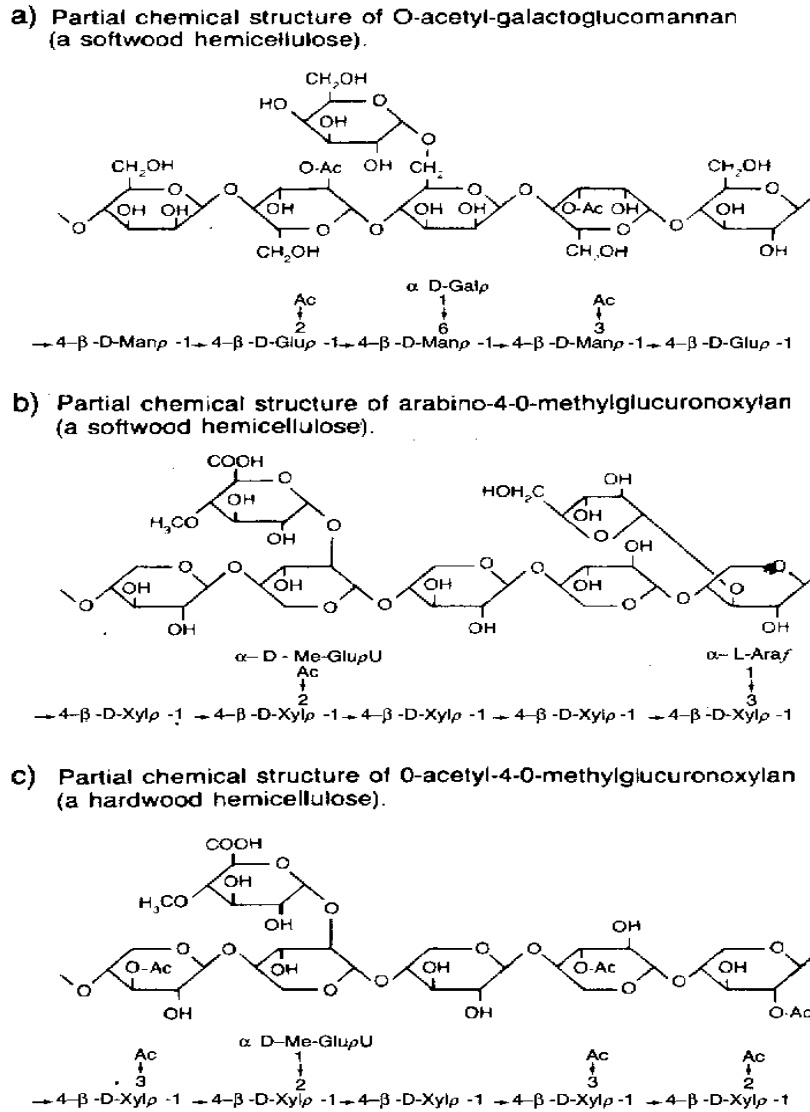

Figure 3: Model structures of hemicelluloses (Fengel & Wegener, 1984)

### **3.3 Thermal degradation of biomass components**

When biomass is subjected to high temperatures, changes occur in its chemical structure and the major components are degraded. These changes are heavily dependent on form of the material, as well as on process parameters, such as the heating rate. When biomass such as wood is progressively heated to higher temperatures, various degradation products are produced. Loss of water and volatile components takes place at temperatures below 140°C. When the temperature rises above 140 °C, the production of CO<sub>2</sub> and CO can be detected (Hill, 2006).

Hemicelluloses are known as the most thermally unstable biomass component. Bourgeois *et al.* (1989) reported that the degradation of hemicelluloses increases with temperature and heat residence time and happens between 100°C and 200°C.

Cellulose degradation, on the other hand, occurs at significantly higher temperatures, because of the crystalline structure of cellulose. It degrades in a temperature range of 300-340°C (Kim *et al.* 2001). Amongst the major components of the cell wall, lignin is accepted to be the most thermally stable, although lignin degradation stretches over a wide temperature range starting at 180°C (Hill, 2006).

Generally, all volatile matter is released at temperatures above 450-500°C. The remaining material is char coal (Beall and Eickner, 1970).

## **4. BIOMASS PROCESSING**

### **4.1 Preparation of wood and agricultural residues for densification**

For any application, the biomass needs to be thoroughly prepared, in order to meet various system requirements. Before any further processing, pre-treatment of the feedstock into particles of uniform size and moisture content is very important. Generally a moisture content of around 10-20 % is ideal for compression. Raw materials with higher moisture content need to be dried, to attain the desired moisture level. The calorific value of woody biomass with around 15% moisture content is in the range of 15.5-16.5 MJ/kg. Comminution into small particles that can be further compressed into pellets or briquettes is done by a hammermill or

other refiners. Larger particles, such as branches or slabs are usually chipped or shredded before milling. Biomass sometimes harbours foreign objects, such as metals; therefore precaution is necessary to eliminate these objects. Some chippers or mills are fitted with metal detectors in order to eliminate metals, which might damage processing equipment (Sims *et al.*, 1988).

## 4.2 Briquetting and pelleting

Apart from the size, there are no significant differences in physical properties between briquettes and pellets. Briquettes are made of coarser particles, while pellets are made of finer particles.

Loose materials with a density of around  $200 \text{ kg/m}^3$  can be processed into briquettes with a density of about  $1200 \text{ kg/m}^3$ . Briquettes intended for use as energy feedstock should have an optimal density of  $900 - 1200 \text{ kg/m}^3$ . According to DIN 51731, the optimal moisture content of wood to make briquettes and pellets is 12%. A higher MC hinders compression of the briquettes, as steam will evaporate from the briquettes, causing them to disintegrate (Clauß, 2002). A too low MC will result in unstable, crumbling briquettes, because not enough water is available to form hydrogen bonds between particles.

In a briquette or pellet, the individual particles can still be observed, their size depending on the milling method employed. Van der Waal's forces, valence forces or interlocking are elemental for the mechanical strength of the compacted material.

When biomass is densified under pressure, mechanical interlocking and increased adhesion between particles occurs. The contact area between these particles determines the amount of possible intermolecular bonds. In wood, for example, the lignin is softened under pressure and forms an adhesive layer between the particles. The type of interaction and the biomass characteristics thus determine the strength of agglomeration and some materials need additional binding agents in order to form stable briquettes or pellets (Mishra, 1996).

Industrial briquetting methods of biomass can be traced back to the 19<sup>th</sup> century. In 1865, it was reported that peat was used to make briquettes. This machine was then further used to make briquettes from other material, including coal fines and brown coal.

Briquettes are commonly made in piston or screw presses (Figure 4), which produce briquettes with uniform density and stability and the utilization of these machines is gradually

increasing especially in European countries and China (Zeng *et al.*, 2007). The pressure in industrial presses is typically about 100 MPa and the resulting briquettes have densities between 800 and 1200 kg/m<sup>3</sup> (in contrast to 60-180 kg/m<sup>3</sup> of the original biomass) with a length of 3-20 cm (Maciejewska *et al.*, 2006).

Frictional forces that occur in the die are responsible for heating the material as it is pushed down to the base of the die. This temperature must be high enough to allow the lignin present in the biomass to flow. The lignin then binds the particles together, forming cylindrically shaped briquettes of uniform size (FAO, 1990) and solidifies again when it leaves the die, resulting in mechanically stable briquettes. When the pressure is increased, the density of the briquettes is also increased, alongside with their energy value (Lindley and Vossoughi, 1989; Clauß, 2002).

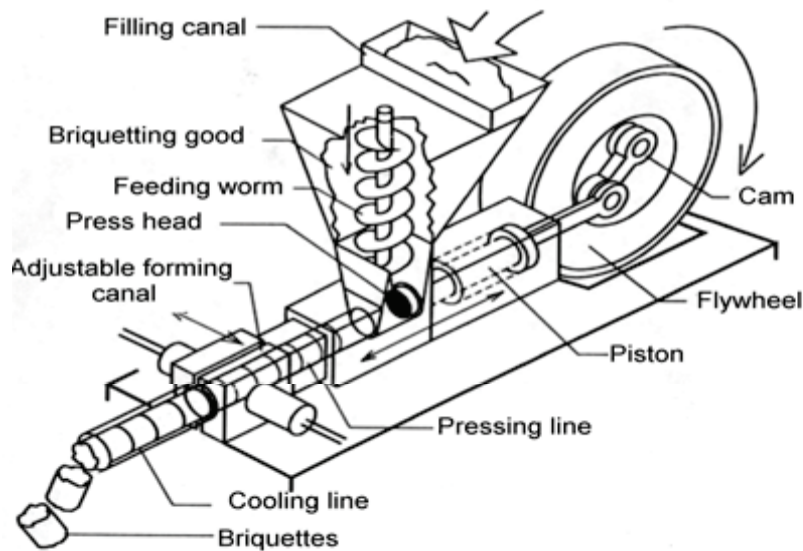

Figure 4: A typical briquette piston press

Other types of briquette presses include the screw press and the roller press. Table 4 shows the technical properties of those machines.

**Table 4: The technical features of briquetting and pellet machines**

<b>Machine type</b>	<b>Common throughput range (t/h)</b>	<b>Specific energy demand (kWh/t)</b>	<b>Product density (kg/m<sup>3</sup>)</b>
Piston press	0.1-1.8	50-70	300-600
Roller press with circular die	3-8	20-60	400-700
Cog-wheel pellet principle	3-7	20-60	400-600
High pressure piston press	0.04-0.2	508-646	650-750

*Source: FAO, 1990; FNR, 2000).*

A small scale, low-pressure compression setup is the hydraulic press, where the main force of compression is axial. Clauß (2002) reported that cotton stalks can be compacted under a modest pressure of 0.5 to 7 MPa (70 bar) without using any binding materials. This pressure range can be reached in manually pressed briquettes using a hand press. The average density of these briquettes was about 900 kg/m<sup>3</sup>.

In this project a small, manual laboratory press - with a maximum pressure of 19.6 kPa per briquette - was used to compress the biomass. In order to compensate for this lower pressure and obtain briquettes of similar stability the press time had to be increased in the experimental setup. There are also no frictional forces present that would allow lignin flow – for this reason the moisture content had to be modified, in order to facilitate more hydrogen bonds between particles.

### **4.3 Properties of Briquettes and Pellets**

Briquettes and pellets are mostly cylindrically shaped and some briquettes have a hole in the middle. Pellets are smaller in size with a comparatively larger surface area. The bulk density of pellets and briquettes is higher if low density biomass is used, because it is easier to



compress. Studies indicate less stability problems for pellets than for briquettes (Larsson *et al.*, 2008).

Briquettes typically have a bulk density of 800-1200 kg/m<sup>3</sup> and pellets of 650 kg/m<sup>3</sup> (Amaya *et al.*, 2007). Studies conducted by Ottawa *et al.*, (1992) and Nakagawa *et al.*, (2003) reported typical briquette surface areas of 600-1200 m<sup>2</sup>/g but these can be as high as 2000 m<sup>2</sup>/g.

The typical calorific value of briquettes and pellets is between 14.6-18.8 MJ/kg at 12-15% MC.

## 5. BIOMASS GASIFICATION

Biomass gasification was intensively used to operate farm and transportation systems during the World War II. It can be described as a process that involves incomplete combustion of biomass to produce combustible gases, which include carbon monoxide, hydrogen, methane and tar. This blend is called producer gas, which can be utilized to run internal combustion engines, to substitute furnace oil in direct heat applications or to produce methanol for industrial or heat engines (Rajvanshi, 1986).

Historically, gasification was conducted at low temperatures where biomass was partially combusted or oxidized. Partial combustion or biomass oxidation yields a low energy content gas compared to gasification. The quality of the gas derived from partial combustion was usually poor, as it contained impurities and too much fuel was required to power any system. Over the decades, gasification has been improved and is now a highly efficient thermochemical technology of converting biomass into energy. If conducted in accordance to system specifications, the technology is capable of performing at more than 70% efficiency (Demirbas, 2004). Gasification is a thermochemical conversion process, in which the fuel is converted into a combustible producer gas. The product of gasification is either a low- or medium - Btu gas depending on the process employed. This producer gas retains about 70-80% of the original biomass energy.

Walker (2006) reported that the process of gasification occurs by heating biomass to high temperature (1200 – 1400°C) in an oxygen deprived environment, therefore limiting combustion. The process takes place in four stages: drying, devolatilization, gasification and finally combustion. The first phase of heating and drying is unproductive in terms of energy

output, as energy is used to evaporate remaining moisture from the biomass. In the pyrolysis phase volatile components of the biomass are removed. The temperature range in this stage is 450 – 600°C. Pyrolysis vapour is comprised of water, carbon monoxide, hydrogen, methane, volatile tars and carbon dioxide. The remaining biomass is a carbonized solid fuel – charcoal, with 10 - 25 % of the original fuel mass. The final stage at temperatures between 700°C - 1200°C involves the conversion of char into producer gas that constitutes about 16% CO, 20% H<sub>2</sub>, 50% N<sub>2</sub>, 12% CO<sub>2</sub> and 2% CH<sub>4</sub> and products such as ash and powder slag (Torres ,2007).

## 5.1 Gasification reactions

The generalized gasification reaction for wood may be written as follows:

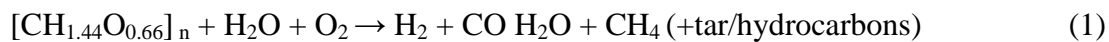

The ratio of hydrogen or oxygen to carbon is almost constant in all wood types and the reaction equation can therefore be presented by the same formula. Where air is utilized rather than oxygen, the resulting gas mixture will contain nitrogen and be less valuable for an effective combustion. Equation (1) is a combination of various complex reactions. The more significant ones, after devolatilization, can be divided into two groups. The first group is the char gasification reaction:



The second group is the gas phase reaction. Light gases (hydrogen and carbon monoxide) are formed during this phase:

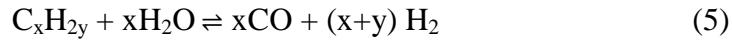

Tar breakdown reactions into simpler gases also take place, depending on the time in the reactor:



The final gas mixture consists of hydrogen, carbon oxides, water, tar/hydrocarbons and heavier hydrocarbons. The gasification process is generally endothermic, which implies that it requires an energy input (Walker, 2006).

## 5.2 Types of gasification reactors

Gasifiers are available in different types and sizes, and run on various types of feedstock including wood, straw, charcoal, coal, rice husks and agricultural wastes. The maximum power output of a gasifier is about 80 MW. Updraft (fixed bed) gasification systems are an old technology and were first installed in 1839 and used for coke and coal combustion. Before the Second World War, fluidized-bed wood gas generators were utilized to power combustion engines and automotive applications. Renewed interest in biomass gasification became evident after the energy crisis of the 1970s'. It is further reported that the biomass gasification technology was known as a relatively affordable alternative for small industrial power generations (Chopra and Jain, 2007).

Gasifiers are classified by the way in which air, oxygen and/or steam is introduced into the system. The choice of one gasifier over another depends on factors such as the type of feedstock, its moisture content, ash content and finally the form of the fuel (Rajvanshi, 1986).

The three most common types of gasifiers are updraft, downdraft and the fluid-bed gasifier (Walker, 2006).

### ***5.2.1 Updraft or counter current gasifier***

The updraft gasifier is the simplest and oldest type of gasification reactor. It derived its name from the fashion in which the oxidant is fed through the reactor. The biomass fuel is loaded through the top into the reactor and moves downwards through the different stages of gasification through gravitational forces, as displayed in Figure 5. The oxidant (usually air, oxygen or a mixture of air and steam) is fed from the bottom of the reactor, from where it moves upwards and gets in contact with the biomass. Combustion reactions occur at the bottom near the grate. Pyrolysis of the fuel occurs in the higher parts of the gasifier at temperatures between 350 – 800°C, because the heat is transferred upwards from the lower combustion zones. In the pyrolysis zone light gases, tars and solid char are formed, which are further gasified in the reduction zone and result in light gases, which are collected from the top of the reactor. The remaining char is transferred to the combustion zone and completely combusted. Ash is then removed from the bottom of the system.

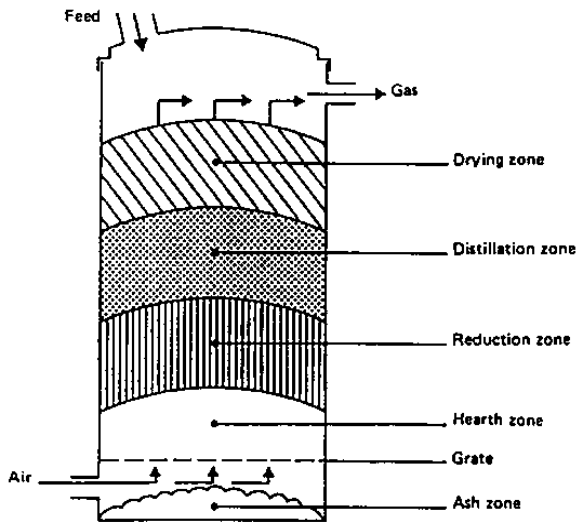

Figure 5: Updraft or counter current gasifier. Gas leaves at the top and oxidant intake occurs through the bottom

This type of a gasifier has numerous advantages such as simplicity, easy internal heat exchange and high charcoal burnout. These qualities lead to high reactor efficiency, as well as compatibility to operate with many types of fuels (FAO, 2001). The reactor can operate with biomass having moisture content as high as 60% on a wet basis. The reactor typically yields producer gas with a calorific value of 1.80 to 3.33 MJ/kg, when oxidized with air. Oxygen as the oxidant in updraft gasification reactors produces higher calorific value gases of between 5-11 MJ/kg (Bridgwater, 1995). Milne *et al.*, (1998) found that the tar composition of the system is approximately 0.0050 to 0.0150 kg/m<sup>3</sup>.

A major disadvantage of the updraft gasifier is diffusion inside the system that leads to high amount of tar production. This could result in explosions caused by oxygen break-through. Tar disposal and cleaning of the reactor are also problematic and the producer gas requires intensive cleaning for applications in turbines and/or engines.

### 5.2.2 Downdraft or Co-Current Moving Bed gasifiers

In the downdraft gasifier, fuel is also fed from the top and gravitates in the packed bed where it is gasified (see Figure 6). Air, oxygen or a mixture of air and steam is fed either from the top or the middle of the reactor and the gasification zones are similar to the updraft reactor. The producer gas is, however, removed from the bottom part of the reactor. Devolatilization

of the biomass occurs in the pyrolysis zone, which is heated by convection and radiation from the lower hearth zone, where temperatures reach 1200C. The hearth zone is embedded on top of the reduction zone, to which char is transferred and gasified (Brown, 2006).

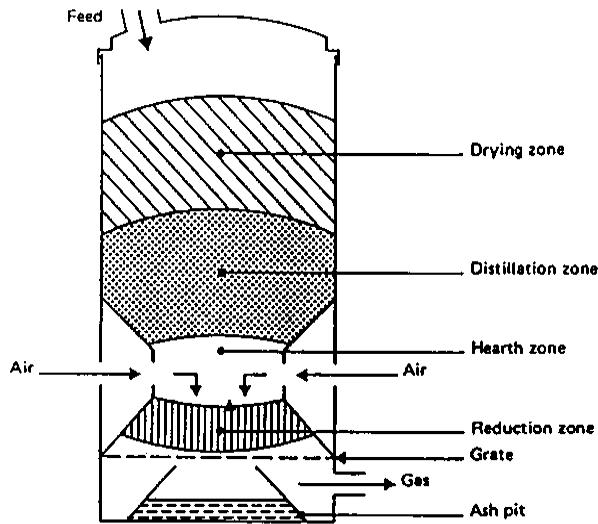

Figure 6: Downdraft or co-current gasifier. Gas leaves the reactor at the bottom

The producer gas obtained from a downdraft reactor contains less tar because the gasses are passed through the hot oxidation zone. The breakdown of tars depends on the temperature of the oxidation zone and the residence time therein.

The reactor requires fuel with a uniform size to prevent slagging and blocking. The type of oxidant used has strong effects on the calorific value of the fuel gas produced. Typically, the calorific value of the gas is about 1.80 to 3.33 MJ/kg aerated with air and roughly 6-7.1 MJ/kg when oxygen is used. The system produces tar with an amount of 0.0001-0.00025 kg/m<sup>3</sup> (Bridgwater, 1995).

### 5.2.3 Fluidized bed gasifier

Fluidised bed gasifiers show a variety of benefits absent in the other reactor types, such as capability of handling large amounts of biomass feedstock, high temperatures and good mixing of the solid phase. These properties offer uniform temperatures and an increased reaction rate, which leads to the production of consistent producer gas. The operation of

fluidised bed reactors is not affected by the physical, morphological and chemical properties of the fuel as opposed to both up- and downdraft gasifiers. The design of a fluidised bed gasifier is schematically illustrated in Figure 7.

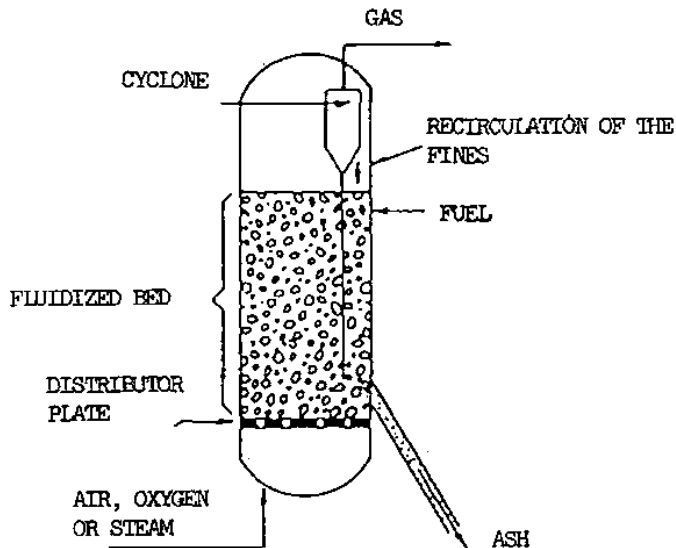

Figure 7: Fluidized bed gasifier

The fluidised bed reactor is composed of a bed of small (1 to 5 mm) sand particles suspended in air, steam or oxygen. Ingestion of biomass occurs into this bed in a temperature range of 700 - 900°C. This peak temperature is reached through external heating of the bed. Fuel particles with the size of 1 - 5 mm are fed into the reactor and spontaneously heated up to the bed temperature. This leads to a fast pyrolysis of the material, resulting in a mixture of components including producer gas. An internal cyclone prevents char from blowing out and re-circulates material back to the main reactor for conversion.

Van der Aarsen *et al.*, (1982) reported that the major advantage of fluidised bed gasifiers is their feedstock flexibility, ease of temperature control, which can be maintained below the melting point of ash. They can be fed with finely milled biomass material, such as sawdust without any prior compression.

Disadvantages of the fluidised bed reactor are: a high tar content ( $\sim 0.0005 \text{ kg/m}^3$  gas) in the producer gas and a poor reaction to changes in fuel quantity and a slow carbon burnout. According to Bridgwater (1995), the energy content of the producer gas from fluidised bed gasifiers is similar to that of updraft reactors. It yields low to moderate calorific value

producer gas, 0.4-0.6 MJ/kg with air as oxidant, 0.8-1.43 MJ/kg with oxygen and 1.2-2.04 MJ/kg when steam is used.

## **6. EXPERIMENTAL SETUP**

### **6.1 Biomass Collection and Preparation**

Grape skins and chicken litter were collected from a trial farm in the Western Cape that aims to be independent from the national electricity grid and wants to produce electricity by gasifying available agricultural residues and wood especially planted for energy purposes. The available biomass in this case was grape skins and chicken litter. The grape skins and chicken litter were obtained from the disposal site of local farms.

The material was found piled randomly at the site. The material was separately placed in two 50 kg bags. Due to the seasonal rainfall prior collection, the material was too wet and sun-drying was done for 72 hours. For the all the material, there was no specific variation or whatsoever sorted in terms of colour, size, composition or species. Pine and eucalyptus wood chips were randomly collected from the Department of Forest and Wood Science, Stellenbosch University. For the following experiments a wood blend of Pine and Eucalyptus wood was used. Wood was first chipped with a Wigger pilot scale chipper and further comminuted with a Retsch mill. Particles were not screened for size in order to simulate the “real-life” scenario at the farm.

Grape skins and chicken litter were cleared of large foreign objects, such as stones and twigs, before preparation. The moisture content of all biomass was determined after milling with the oven-dry method and moisture was either added or reduced (by further drying), where necessary, to obtain the desired moisture content.



## 6.2 Laboratory Press

The briquettes were pressed with a custom built hydraulic laboratory press (Figure 8) that consists of a car jack with a maximum load of 8000 kg when fully extended. A single briquette has a diameter of 8 cm, which means the maximum pressure on one briquette when the press is fully closed is 19.6 kPa. The resulting briquettes had a height of about 3 cm respectively.

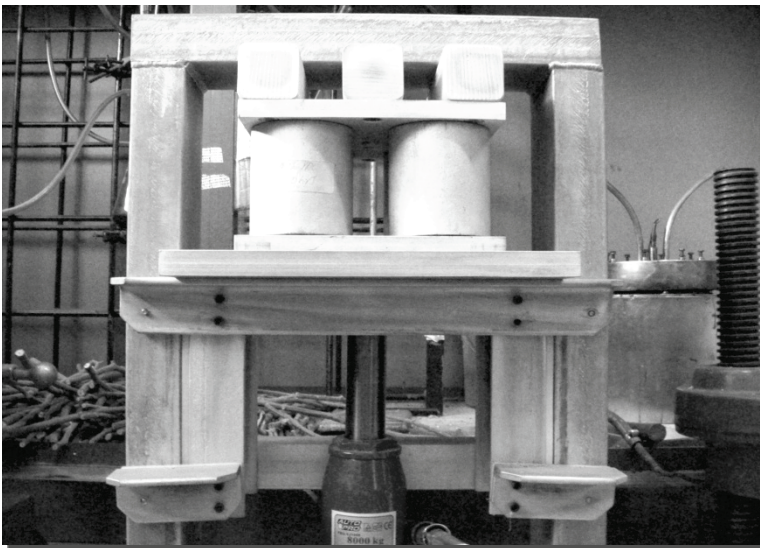

*Figure 8: Laboratory briquettes press*

Because the pressure in this manual press is significantly lower than the pressure obtained in industrial presses and no friction is produced in the process that could heat the lignin above its glass transition temperature, the optimum press settings with regards to moisture content (MC) and press time had to be determined in order to produce mechanically stable briquettes. For this, batches of the individual biomass components were produced with different moisture contents and pressed at various times.

## 6.3 Stability and Density

The stability of the resulting briquettes was observed visually after two weeks of conditioning at 20°C and 65% Relative Humidity.

The density was determined directly after pressing and after two weeks conditioning by measuring the dimensions of the briquettes and weighing them. The highest density and the best stability were taken as indicators for optimum press settings.

## 6.4 Biomass

### 6.4.1 Wood

Eucalyptus (hardwood) and pine (softwood) were used in this study to produce briquettes. Figure 9 shows typical wood briquettes.



Figure 9: Lab pressed wood briquettes

Eucalyptus is a hardwood species that is widely grown throughout the world for timber, fuel, essential oils and is primarily native to Australia and Tasmania. Calorific values determined for *Eucalyptus grandis*, *saligna* and *globulus* ranged from 18.89 to 19.25 MJ/kg and there is no significant difference in the energy content of various Eucalypt species (Forrest & Moore, 2008). Table 5 indicates typical characteristics of eucalyptus compared to straw.

**Table 5: Fuel analyses and characterization**

<b>Fuel</b>	<b>Eucalyptus wood</b>	<b>Straw</b>
Proximate analysis (%)		
Moisture	9.37	10.85
Ash	2.17	4.18
Volatile matter	76.87	81.11
Fixed carbon	11.29	3.87
Ultimate analysis (%)		
Carbon	53.44	50.74
Hydrogen	5.44	5.36
Oxygen	40.73	-
Nitrogen	0.26	0.58
Sulphur	0.08	0.15
Energy content (MJ/kg)	19.25	15.66
Briquette bulk density (kg/m <sup>3</sup> )	638	567

*Source: Olanders and Steenari, 1995*

The syngas produced by gasification of wood contains approximately 11-13% CO<sub>2</sub>, 15-21% H<sub>2</sub>, 10-20% CO and 1-5% CH<sub>4</sub> (Akudo, 2008).

#### **6.4.2 Grape skins**

Grape (*Vitis vinifera* L.) skins and seeds are the by-products of the wine industry. They are organic, biodegradable material that could be pressed into briquettes to produce biofuels, therefore adding value to the waste.

According to a report by the International Organization of Vine & Wine (2005), over 67 million tons of wine grapes were harvested globally during the year 2005. Grape residue is an all inclusive term that includes the stalks, redundant skins and seeds that remain after the grape juice has been extracted. Tsai *et al.*, (2006) explained that the grape residues are composed of a large amount of cellulose and hemicelluloses with high energy content. The properties of grape skins and grape skins with seeds are illustrated on Table 6.

**Table 6: Properties of grape residue feedstock**

Characteristics	Grape skins	Grape skins and Seeds
Proximate Analysis (wt %)		
Moisture	6.26%	51.44%
Ash	6.36%	2.05%
Fixed Carbon	23.31%	6.33%
Volatile Matter	64.07%	0%
Ultimate Analysis (wt %)		
Carbon	47.36%	6.29%
Nitrogen	2.25%	5.66%
Hydrogen	5.88%	26.12%
Sulphur	0%	61.93%
Oxygen	44.41%	40.18%
Apparent density (kg/m <sup>3</sup> ) grape skins/seeds	0.56	0.57
Energy content (MJ/kg)	18.6	19.8

Source: Xu *et al.* (2009).

Disposed grape residues consist of grape skins, seeds and foreign objects and they normally have high moisture content. This implies that air drying and fractionating of the material to separate grape skins from undesired material is necessary for further processing.

The grape skin constitutes about 5-12% of the total weight of the grape. The skin consists of 6-10 layers that make up the epidermis. The skin is covered with cutin, which forms a thin wax-like layer that constitutes about 1 - 12% of the grape skin weight. It contains aldehyde esters, fatty acids, and traces of paraffins. The main function of the cutin is to protect the fruit against water loss and infestation from other organisms. Most of the colour- and flavour-producing agents of the grape are located in the skin and cell-layers beneath the cutin. Large amounts of tannin are normally found in red grapes (Winkler *et al.*, 1974). The cell walls contain interlocked microfibrils that consist of hemicelluloses, pectins and structural proteins constituting 30-40% of the polysaccharides in the grape skins. Other components in grape skins are galacturonic acid and glucose (Ortega-Regules *et al.*, 2006). Notable is the absence of lignin in grape skins, which could constitute a problem for the compression into briquettes.



Figure 10: a) Grape residue and b) grape skin briquettes

### 6.4.3 Chicken litter

According to reports by Mukhar (2002) and the Maryland Environmental Service (1999), chicken litter has a high potential as a viable biofuel. They report that the calorific value of chicken litter is on average 9.5 MJ/kg at a moisture content of around 25%. Chicken litter is waste from the poultry industry and it includes chicken excreta, litter or bedding material (e.g. wood shavings or straw), feed and feathers. The composition of chicken litter is thus highly heterogeneous with varying chemical and physical properties such as ash and water

content. The ash composition of chicken litter is usually very high, because of the high potassium content. When cotton straw is used as bedding material for instance, the potassium content could be as high as 4-6%, while for wood shavings it could be below 1.5%. The chicken litter used in these experiments contained wood shavings. The nitrogen content of chicken litter is also high and appears in the form of ammonia nitrogen or inorganic nitrogen (Dagnall, 1993).

The moisture content of chicken litter is typically above 40%, leading to a serious decrease in combustion efficiency. Dry samples of chicken litter were reported to have a typical energy content of 13.5 MJ/kg (Abelha *et al.*, 2003).

**Table 7: Properties of chicken litter**

<b>Component</b>	<b>Value</b>
Moisture (%)	42
Ash (% db)	34.29
Carbon (% db)	32.71
Hydrogen (% db)	3.94
Energy content (MJ/kg)	13.50

*Source: Abelha, Gulyurtlu et al. 2003).*



*Figure 11: Chicken litter a) and b) chicken litter briquettes*

The briquettes produced from chicken litter were the most mechanically stable compared to wood and grape skins, as can be seen in Figure 11 b.

## 6.5 Physical Properties of Briquettes

### 6.5.1 Ash Content

The ash content was determined according to TAPPI standard T 211 om-85 (1985). Oven-dried pieces of the briquettes were weighed before they were placed in a furnace at 575°C for 3 hours. After combustion the samples were placed in a desiccator to prevent moisture absorption while cooling. The ash content was determined according to:

$$\text{Ash content} = m_{\text{ash}} \times 100/m_{\text{ovendry}}$$

### 6.5.2 Energy Content

The energy content or calorific value of oven-dried biomass was determined in an ECO bomb calorimeter from CAL2k (see Figure 12).

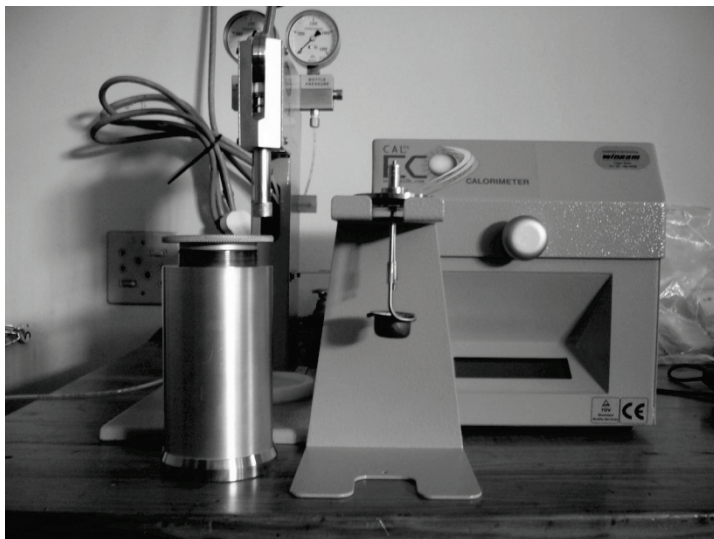

Figure 12: CAL2K-ECO bomb Calorimeter

The instrument was calibrated with about 0.5g of benzoic acid before measurements. The energy content of about 0.5g of the biomass optimised briquettes (wood 12 hours/14% MC; grape skins 10 hours/14% MC & chicken litter 11 hours/14% MC) was determined in a pressurized oxygen atmosphere of 3000 kPa. The energy content is determined from the raise in temperature of the vessel after complete combustion of the biomass.

### **6.5.3 Thermogravimetric analysis (TGA)**

TGA was employed to determine the thermal degradation and the fraction of inorganic material by observing and monitoring changes in weight, as the sample is combusted. TGA profiles were determined with a Q-500 thermo-gravimetric (TG) analyser (Figure 13).



*Figure 13: Q-500 Thermogravimetric analyzer*

About 50 $\mu$ g of each sample were degraded in a nitrogen atmosphere over a temperature range from 0-600 $^{\circ}$ C increasing with a rate of 23.02 $^{\circ}$ C/min. Three types of biomass (chicken litter, grape skins and wood) and the optimum blend of all three materials were subjected to TGA.

### **6.5.4 Elemental Analysis**

One of the most important properties of biomass is its elemental composition because it indicates the theoretical energy content. The proximate and ultimate analyses of biomass are necessary to simulate the efficiency of an energy conversion system, such as gasification.



The chemical composition of wood, grape skin, chicken litter and blended briquettes was determined with regards to carbon, nitrogen, sulphur and silicon content. The carbon content was determined by the Walkey-Black method, in which the sample is digested in sulphuric acid. The nitrogen content was determined via dry combustion on a LECO Nitrogen Analyzer. The sulphur content was determined by digesting the samples in nitric acid and the silicon content was determined inductively coupled plasma atomic emission spectroscopy (ICP-AES).

## **7. GASIFICATION AND SIMULATION OF EXPECTED PERFORMANCE**

About 20 kg of briquettes made from the optimum blend of materials were produced for gasification and the expected performance was first modelled with modelling software especially developed for downdraft gasifiers. The gasification tests were performed at the University of Fort Hare, at the Institute of Technology.

### **7.1 Gasification Reactor**

The briquettes were tested for their performance in a small-scale downdraft gasifier at the University of Fort Hare (Figure 14). The gasification reactor has an inner diameter of 0.89 m and is 1.25 m high. The internal reactor has a maximum feed input of about 70 kg depending on the bulkiness of the material. The inner and outer walls of the drum are 1.5 mm thick galvanized iron, respectively. The fuel is fed into the reactor through the top loading zone. Ignition was done by inserting a few party sparklers, locked in a sparkler holder with a handle, through the igniter sleeve. The gasifier simulation tests showed that it could reach sufficiently high temperatures to yield adequate producer gas in both the combustion zone (100-450°C) and gasification (450-845°C).



*Figure 14: Prototype downdraft gasifier (open)*

## **7.2 Reaction Simulation**

### ***7.2.1 Chen's simulation model***

A modelling program that was developed by Chen (1987) was used for the simulation of the gasification performance of the briquettes produced in this project and pine wood, respectively. The gasification yield of the briquettes was simulated with the model developed by Chen (1987), which was later adjusted by Jahah (2002) to suit downdraft gasifiers.

The prime objectives of Chen's model were to project and estimate parameters of a downdraft gasifier, such as its reactor diameter, length and size of the gasification zone. The model was also developed to investigate the effect of other operating parameters, such as the fuel/feedstock size, moisture content, density, diameter, elemental composition, input air temperature and gasifier load per run on the reactor performance.

The gas output results obtained from Chen's model are comparable with other literature experiments presented by Graham and Huffman (1987) for industrial scale downdraft biomass gasifiers. A comparative review of predicted gas composition from Chen's model and typical experimental results presented by Graham and Huffman (1981) is given in Table 8. Chen's model is thus applicable for the simulation of biomass performance in downdraft gasifiers.

**Table 8: Comparative results of Chen's model with Graham and Huffman**

Gas composition (% vol.)	Chen's model	Typical range reported by Graham and Huffman
CO	18.5	11.9-26.3
H <sub>2</sub>	15.8	8.9-18.0
CO <sub>2</sub>	12.8	9.1-17.7
N <sub>2</sub>	48.7	41.5-54.7
CH <sub>4</sub>	2.6	2.1-3.5
Trace	1.6	1.5-2.6

*Adopted from Jahah (2002)*

The gasifier conversion efficiency was simulated using the optimum range of operating and design parameters. The anticipated yield for the briquettes was modelled with the aid of the above mentioned program. Briquettes parameters such as the moisture content (MC), carbon (C), hydrogen (H), oxygen (O), nitrogen (N), fixed carbon (FC), bulk density (BD) and fuel diameter were input parameters for modelling.

The experimentally determined parameters for the briquettes and the gasifier in Fort Hare are given in table 9.

**Table 9: Experimentally determined parameters of briquettes and pine wood with gasifier operating conditions.**

<b>Parameters/dimensions</b>	<b>Briquettes</b>	<b>Solid pine wood</b>
<b><i>Briquettes &amp; pinewood Proximate Analysis (wt %)</i></b>		
%MC	12	15
Carbon	22.81	54.41
Fixed Carbon	1.6	12
Hydrogen	5.4	5
Oxygen	41	37
Nitrogen	1.92	0.22
Density ( kg/m <sup>3</sup> )	670	926
Fuel diameter/cm	8	12
<b><i>Gasifier parameters</i></b>		
Throat diameter/cm	5	5
Throat angle (deg.)	30	30
Insulation thickness/cm	2	2
Thermal conductivity (w/cm K)	2	2
Temperature (Input air)/ <sup>o</sup> C	27	27
Feed input (kg/hr)	65	65
Air input (kg/hr)	44.5	44.5
% Heat loss	0.5	0.5

## 8. RESULTS AND DISCUSSION

### 8.1 Press Settings

The first part of the project was the determination of optimum press settings for the laboratory press that would yield mechanically stable briquettes. Briquettes were pressed with moisture contents ranging from 0-24% at press times between 0-24 hours. Evaluation of the briquettes was done visually, by determining the degree to which they crumbled and by measuring their density. Figure 15 shows stable and unstable briquettes. Only stable briquettes were selected for further analysis.



Figure 15: a) Stable and b) unstable briquettes

Table 10 shows the density values determined for wood (W), grape skins (G) and chicken litter (C) briquettes obtained with the various settings. The five best settings for each system are labelled 1(best) - 5 and the final optimum press settings were chosen as those, where equally good values for all three components were obtained. Briquette densities ranged from 300 to 550 kg/m<sup>3</sup> for wood briquettes, 600 to 800 kg/m<sup>3</sup> for grape skin briquettes and 600 to 800 kg/m<sup>3</sup> for chicken litter briquettes.

**Table 10: Density ratings obtained for different press settings and different raw materials**

t(h) \ %MC	2	3	4	5	6	7	8	9	10	11	12	13	...	18	19	20	...	24	
1																			
...																			
7																			
8					W4 0.539														
9																			
10															W1 0.594				
11																			
12																			
13																			C1 0.829
14									G1 0.790	C4 0.701	W2 0.558								
15																			W3 0.556
16	C5 0.574	C3 0.734																	
17																			G2 0.786
18		G3 0.767																	
19																			
20																G5 0.707			
21																			
22							G4 0.748	C2 0.797	W5 0.515										

The optimum press settings entail the highest possible density at a preferably short press time. It can be seen that comparably good results were obtained for all three components with press times around 10-12 hours and at a moisture content of 14%. As biomass can be easily air dried to a moisture content of 12% in the Western Cape, for all following experiments press settings of 11 hours at 12% MC were chosen.

Table 11 shows the ash content and calorific values determined for the individual components pressed at these settings.

*Table 11: Ash content and calorific value of wood, grape skins and chicken litter*

<b>Component</b>	<b>Ash content (%)</b>	<b>Calorific value (MJ/kg)</b>
Wood	0.44	18.977
Grape skins	28.12	18.940
Chicken litter	26.38	12.277

The 0.44% ash content of wood corresponds well with literature values. Grape skins and chicken litter showed very high ash contents - above 25%. This could be explained by their chemical composition and possible contamination with various foreign inorganic objects, as they were stored in the field prior to the experiments.

The calorific value of wood also agrees well with the literature values of various wood species (Munalula and Meincken, 2009). It had the highest calorific value of all three components, closely followed by grape skins. Chicken litter had with 12.3 MJ/kg, the lowest calorific value.

There was no significant difference between the calorific values of the different blended ratios (Table 12). They were slightly lower than for wood or grape skin alone, but in a comparable region. The ash content varied slightly more between 0.66% for the 50:30:20 blend to 1.14% for the 40:35:25 blend.

*Table 12: Ash content and calorific value of briquettes containing a blend of all three components*

<b>Ratio (Wood: Grape skins: Chicken litter)</b>	<b>Ash content (%)</b>	<b>Calorific value (MJ/kg)</b>
40:35:25	1.14	17.25
45:40:15	0.977	16.74
50:30:20	0.664	17.87
60:30:10	0.833	17.26

The briquettes pressed with a ratio of 50:30:20 yielded the highest energy content and at the same time the lowest ash content and can therefore be regarded as the optimum blend.

Considering that wood is the most expensive component and chicken litter the cheapest and probably also the most abundant, this biomass blend shows clear advantages over wood-only briquettes for gasification.

## 8.2 Thermal degradation

The TGA and DTG curves of the four types of briquettes i.e. wood, grape skins, chicken litter and the blend are shown in Figure 16. They show similar trends as reported by Ergudenler and Ghaly (1994), where the three weight loss steps can be observed for all the four samples. The initial weight loss at  $\sim 100^{\circ}\text{C}$  can be assigned to water evaporation, while the second and the third ( $200^{\circ}\text{C}$ - $350^{\circ}\text{C}$ ) are due to the degradation of extractives, hemicelluloses and lignin. The final weight loss ( $350^{\circ}\text{C}$ - $600^{\circ}\text{C}$ ) can be assigned to the degradation of cellulose and lignin because lignin degrades over a wide temperature range. The decomposition of cellulose chains occurs at higher temperatures between  $350 - 600^{\circ}\text{C}$ . The extent of weight loss in the last two regimes differs significantly between the briquette types. Generally, wood and the blend degraded more in the last step, which can be assigned to the final lignin degradation as well as cellulose degradation.

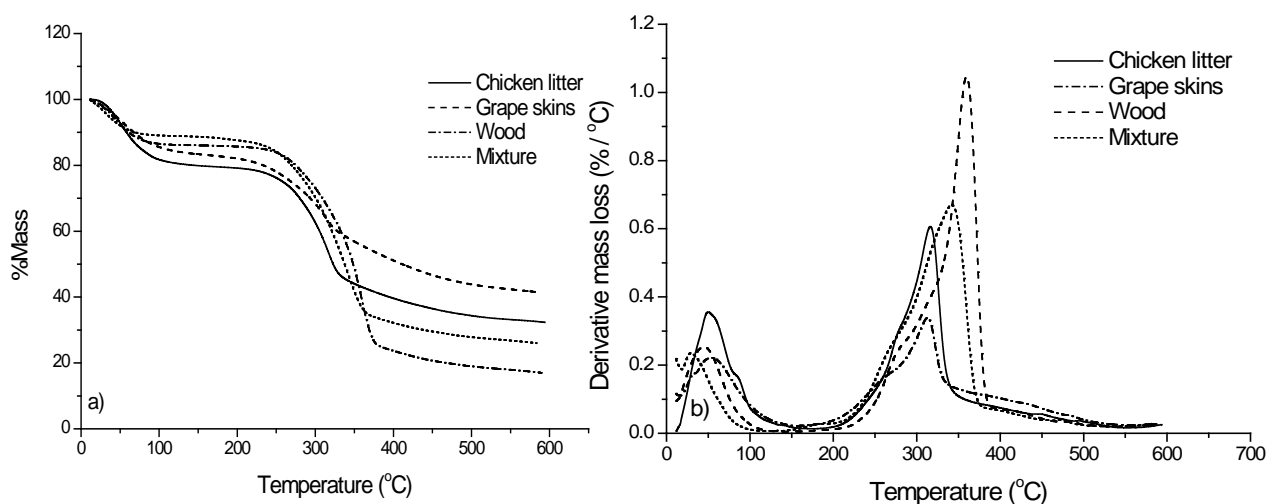

Figure 16: a) TGA curves and b) DTG curves of various briquettes



Table 13 shows the different peak temperatures of the four briquette types determined in the DTG curves, as well as the residual weight at 600°C.  $T_0$  is the first peak, at which degradation starts, while  $T_1$  and  $T_2$  indicate the following shoulders or peaks in the DTG curves that are caused by degradation of the biomass.  $T_f$  indicates the temperature, at which the decomposition of biomass is complete and the mass remains constant.

**Table 13: Different peak temperatures from the DTG curves**

<b>Biomass</b>	$T_0$ (°C)	$T_1$ (°C)	$T_2$ (°C)	$T_f$ (°C)	<b>Residue at 600°C (%)</b>
Chicken litter	89.36	275.37	314.93	508.24	32.43
Grape skins	51.11	263.42	319.06	504.15	41.56
Wood	161.33	250.66	354.42	530.49	17.33
Mixture	190.25	279.56	352.36	566.36	26.26

All DTG curves show a common trend. The first peak up to 100°C can be associated with the evaporation of water. Thereafter, shoulders can be observed around 250°C, which can be assigned to the degradation of hemicelluloses and lignin. The highest value for  $T_1$  was found in the blend, followed by chicken litter, grape skins and wood. Thermal degradation of cellulose and the remaining lignin was observed between 310°C and 350°C. The highest value of  $T_2$  was found in wood, followed by the blend, grape skins and chicken litter. The highest  $T_f$  was found in the blend, followed by wood, chicken litter and grape skins.

This means that the most thermally stable briquettes were the blended ones, followed by wood and finally the grape skin and chicken litter briquettes. This can be attributed to the cellulose and lignin found in the wood and the blend leads to high thermal stability for the briquettes.

The high thermal stability of the blended as well as the pure wood briquettes can be associated to the high cellulose content.

For the gasification a high thermal stability is desirable, because the temperature rise during combustion occurs at a slow rate, thereby increasing the biomass to heat contact ratio. In downdraft gasifiers this leads to a higher energy yield. Biomass with low thermal stability degrades faster, which means more feedstock will be required per hour. The quantity of energy produced from faster degrading biomass is, however, not necessarily larger.

Above 500°C, all samples reached a stable mass with no further degradation. The highest residual mass of 41.56% was found in grape skins followed by the chicken litter (32.43%), the blend (26.26%) and lastly the wood briquettes (17.33%). This can be explained by the fact that grape skins and chicken litter have a high content of inorganic, incombustible material such as soil, stones and some mineral particles.

Generally, the high residue content (compared to the ash content) in all briquette types could further be attributed to the low maximum temperature of 600°C. This temperature was not sufficient for complete biomass combustion.

### 8.3 Elemental composition of briquettes

Carbon, nitrogen, sulphur and silicon content were determined in order to predict the heating performance, as well as the environmental impact of the samples.

*Table 14: Percentage elemental composition*

<b>Sample ID</b>	<b>C (%)</b>	<b>K (%)</b>	<b>N (%)</b>	<b>S (%)</b>	<b>Si (mg/kg)</b>
<b>Blend</b>	22.81	1.29	1.92	0.28	10.12
<b>Chicken litter</b>	29.43	0.76	1.37	0.1	0.13
<b>Grape skins</b>	25.15	1.98	1.76	0.13	0.15
<b>Wood</b>	31.7	0.06	0.26	0.01	0.18

The high carbon content (31.7%) in wood correlated well to the highest energy content of 18.98 MJ/kg. Chicken litter, on the other hand, had the second highest carbon content

(29.43%) but the lowest energy content (12.28 MJ/kg), which could be attributed to the high C: N ratio in chicken litter.

It could also be observed that the blend had the highest nitrogen and silicon content, which can be translated to possible air pollution and gasifier disturbance during conversion. The blend is however, still suitable for energy conversion if monitored for possible process interruptions.

Biomass with high nitrogen and sulphur content leads to the emission of polluting waste gases, such as  $\text{NO}_x$  and  $\text{SO}_x$ , which are toxic to humans and the environment. A high nitrogen content (forming ammonia) can also cause blocked air flow, by corroding pipes and valves of the gasifier.

## 8.4 Gasification

The average fuel moisture content of the briquettes was 12%, which is ideal for gasification. Figure 17 shows the simulated producer gas yield obtained between 722°C and 845°C. The average gas composition was found to be 21.6% CO, 36.08%  $\text{H}_2$ , 14.49%  $\text{CO}_2$ , 1.4%  $\text{CH}_4$  and 26.46%  $\text{N}_2$ . These gases do, however, not present similar energy significance, because some of them are combustible, whilst some ( $\text{CO}_2$  and  $\text{N}_2$ ) are waste gases. Combustible gases are  $\text{CH}_4$ ,  $\text{H}_2$  and  $\text{CO}_2$ .

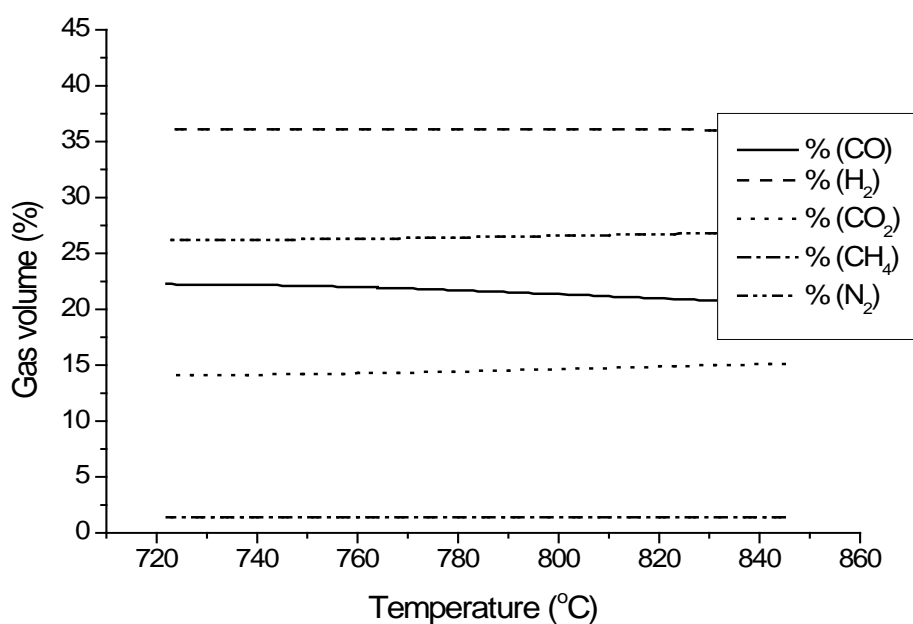

Figure 17: Producer gas yield of briquettes

Figure 18 shows the expected heating value of the producer gas, derived from the composition of all combustible gases contained in the producer gas. The maximum heating value was found to be 6.97 MJ/kg.

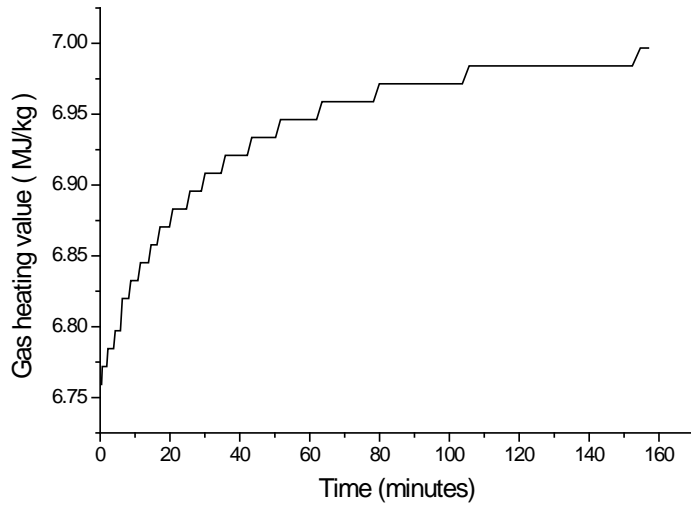

Figure 18: Heating value of the producer gas obtained from briquettes

Figure 19 shows the modelled gasifier/reactor conversion efficiency, which was found to be 81.23% on average for the briquettes.

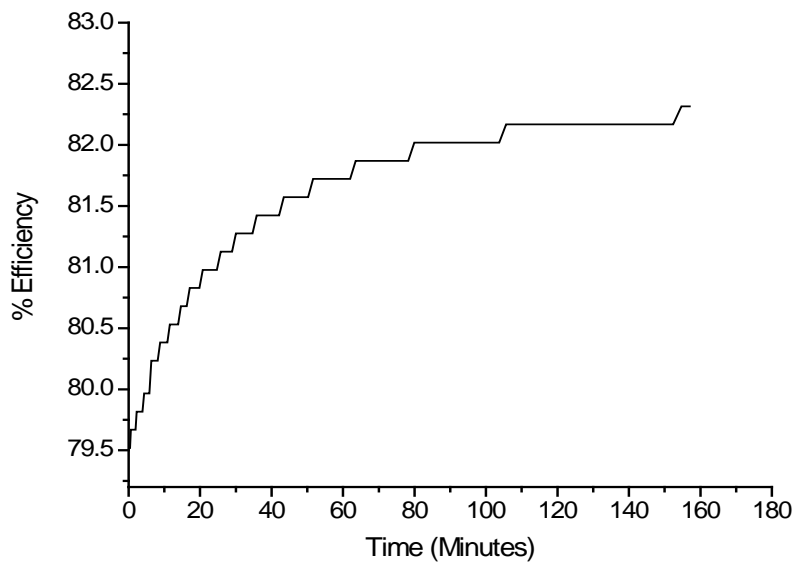

Figure 19: Conversion efficiency of briquettes

## 8.5 Comparison pine wood and briquettes gasification

The gasification yield was also modeled for solid pine wood of the same diameter and MC as the briquettes. The conversion efficiency as well as producer gas yield of solid pine wood was comparatively higher than that of the briquettes. This could be attributed to the higher carbon content, density and energy content (19.5MJ/kg) of pine wood.

Figure 20 shows the producer gas composition of pine wood.

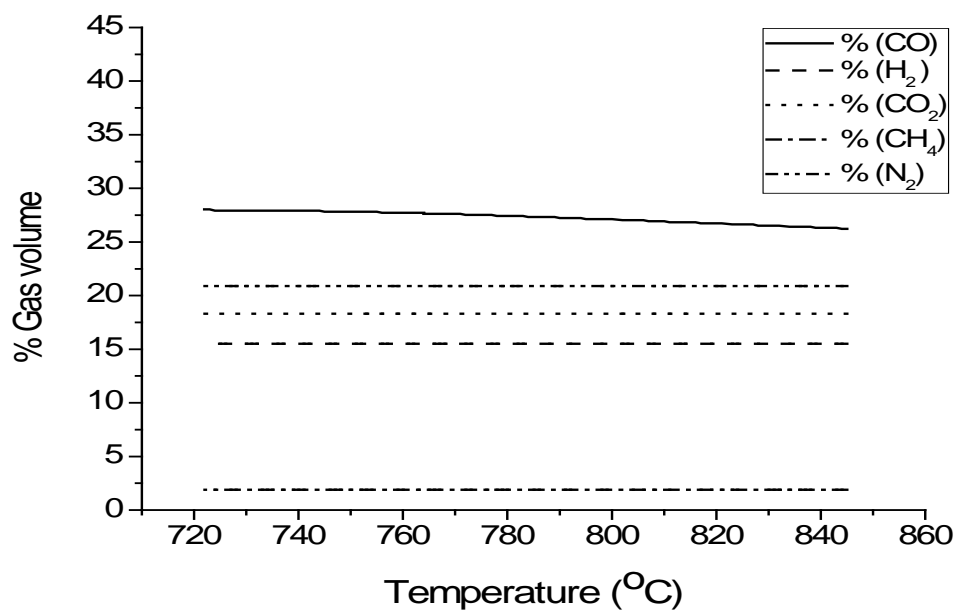

Figure 20: Producer gas yield of pine wood

The producer gas composition obtained from solid pine wood was 1.89% CH<sub>4</sub>, 15.5 % H<sub>2</sub>, 26.23% CO, 18.3% CO<sub>2</sub> and 20.9% N<sub>2</sub> respectively. The CH<sub>4</sub> and CO yields are comparable to the values obtained from our briquettes, but the hydrogen production is considerably higher when pine wood is used.

The maximum heating value obtained for pine wood was with 7.51 MJ/kg comparatively higher than that of the briquettes. Figure 21 represents pine wood gas heating value.

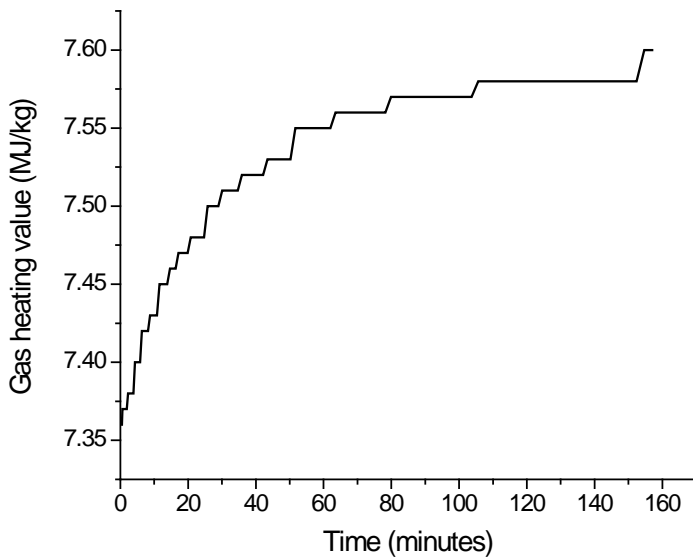

Figure 21: Heating value of the producer gas obtained from pine wood

## 8.6 Gasification of briquettes

The mechanical stability of briquettes was the most important challenge faced during experimental gasification runs. The briquettes were not stable enough to be converted in the gasifier and disintegrated, which led to a process failure. The downdraft gasifier is not adequately equipped to handle very small particle sizes, because they block the air circulation. The majority of briquettes crumbled and disintegrated in the combustion zone before complete combustion could take place. This led to an inadequate air flow and subsequent process failure. The temperature did not raise enough for biomass conversion into producer gas.

The stability of the briquettes could only be improved with higher pressures when compressing the briquettes or added frictional forces that would facilitate lignin flow and bonding. Both were not possible in the used experimental setup used in this project. The option of using binders does not seem necessary, because the briquettes have shown the potential for high stability when pressed with an industrial setup.

## 9. CONCLUSIONS

The processability of three types of biomass, namely wood, grape skins and chicken litter, available as residues on a trial farm in the Western Cape into briquettes was determined in this project. Different press settings resulted in a wide range of density values and varying stability of briquettes. For the laboratory press setup values of 12% moisture content and a press time of 11 hours were found to be the optimum settings. With these settings wood and grape skins performed best and chicken litter reasonably well.

Briquettes pressed with the optimum settings were then tested for ash and energy content, thermal stability and their elemental composition. The ash content of grape skins and chicken litter was with above 25% extremely high. The energy content of wood and grape skins was with about 19 MJ/kg comparable and that of chicken litter considerably lower.

These results suggest that briquettes made from a blend of all three components should consist of as much wood as possible, followed by grape skins with a smaller part of chicken litter. Taking cost into account as well as the ash and energy content determined on various blends – an optimum mixing ratio of 50:30:20 wood: grape skins: chicken litter was found. Briquettes pressed at this ratio showed the highest mechanical stability, and energy- and ash-contents similar to wood briquettes.

The briquettes showed a good thermal stability, which means they can withstand a too fast degradation in the gasifier for extended periods. With regards to elemental composition, chicken litter and the grape skins showed an undesirably high composition of nitrogen, but the composition of the blend was acceptable for gasification.

The composition of combustible gases ( $H_2$ ,  $CH_4$  and  $CO$ ) for blended briquettes was comparable to that of pine wood, which implies that the blend is suitable for conversion in a gasifier. The modelled gas had a maximum heating value of 6.97 MJ/kg, which is adequate.

## **10. OUTLOOK**

If briquettes made from a wood, grape skin and chicken litter blend are to be used on a large scale for gasification they will have to be produced in an industrial briquette press with sufficiently high pressure and frictional forces. The briquettes produced in this project were made in a laboratory scale press and were not stable enough to be converted in a gasifier.



## 11. REFERENCES

1. Abelha, P., Gulyurtlu, I. et al. 2003. Combustion of poultry litter in a fluidised bed combustor small star, filled. *Fuel* **82**(6): 687-692.
2. Adler, E. 1977. Lignin chemistry – Past, Present and Future. *Wood Science and Technology*, *11*(3) 169-218. In Walker, C. F .J. (2<sup>nd</sup> eds.) 2006. Primary Wood Processing: Principles and Practice, P. 25-33.
3. Akudo, C.O. 2008. Quantification of tars and particulates from a pilot scale, downdraft biomass gasifier. The Department of Biological and Agricultural Engineering. Louisiana State, Louisiana State University and Agricultural and Mechanical College. Master of Science in Biological and Agricultural Engineering: 80.
4. Amaya, A., Medero, N., et al. 2007. Activated carbon briquettes from biomass materials. *Bioresource Technology* **98**(8): 1635-1641.
5. Beall, F.C. and Eickener, H.W. 1970. Thermal degradation of wood components: a review of the literature. U.S.D.A. Forest Service Research Paper. Forest Products Laboratory Service 130. May 1970.
6. Bezzon, G. and Cortez, L. 1999. Biomass use in Brazil. Energy and Agriculture towards the third millennium conference 2-5 June 1999, Athens, Greece.
7. BMFT. 1986. *Nachwachsende Rohstoffe (Renewable Agricultural Resources)*. Bundesministerium für Forschung und Technologie, Bonn, Germany.

8. Bossel, U. 1980. "Heizen mit Holz"; Tagungsbericht. 84 (85): 117.
9. Bourgois, J., Bartholin, M.C. and Guyonnet, R. 1989. Thermal treatment of wood: analysis of the obtained product. *Wood Science and Technology*, 23(4), 303-310. In Hill, C.A.S. 2006. *Wood Modification: Chemical, Thermal and other processes*. p.104.
10. Bridgewater, A.V. 1995. The technical and economic feasibility of biomass.
11. Brökeland, R. and Groot, L. 1995. *Nachwachsende Rohstoffe für den Gartenbau (Renewable Agricultural Resources for Horticulture)*. KTBL, Darmstadt, Germany.
12. Brown, J. 2006. Biomass gasification: fast internal circulating fluidised bed gasifier characterization and comparison, Masters Thesis. University of Canterbury.
13. Chen, J.S., 1987. Kinetic engineering modelling of co-current moving bed gasification reactors for carbonaceous material. PhD. thesis, Cornell University. New York.
14. Chopra, S. & Jain, A. 2007. A review of Fixed Bed Gasification Systems for Biomass.
15. Clauß, B. 2002. Beitrag zur Kompaktgierung von unzerkleinertem Halmgut für die energetische Nutzung (Contribution to the compacting of unchopped crop stalks for energetic use) Ph.D. Thesis. TU Chemnitz.
16. Coll, R., Slavado., J. and Montane, D. 1998. Influence of temperature on the ash composition and volatilisation during gasification and combustion of residual biomass.

The 10th European Conference on Biomass for Energy and Industry, June 1998, Würzburg, Germany.

17. Demirbas, A. 2004. Combustion characteristics of different biomass fuels. *Progress in Energy Combustion Science*, 2004; 30:219-30.
18. Ergudenler, A. and Ghaly, A. E. 1994. *Bioresource Technology*. 50, 201.
19. FAO, 1990. The briquetting of agricultural wastes for fuel. Food and Agriculture Organization of the United Nations.
20. Fengel, D. and Wegener, G. 1989. *Wood: Chemistry, Ultrastructure, Reactions*. Walter De Gruyter, Berlin, Germany. In Hill, C.A.S. 2006. *Wood Modification: Chemical, Thermal and other processes*. p. 105.
21. Fengel, D. and Wegener, H. 1984. In Walker, C. F .J. (2nd eds.) 2006. *Primary Wood Processing: Principles and Practice*, page 39-40.
22. FNR, 2000. Fachagentur Nachwachsende Rohstoffe e.V. Leitfaden Bioenergy. (Specialized Agency for Raw Materials) Manual of Bioenergy. Gülzow, Germany.
23. Food and Agricultural Organization of the United Nations (FAO). 2001. *The global Forest Resources Assessment 2000. Summary Report SO-88*. U.N. Food and Agriculture Organization. Rome, Italy.

- 24.** Forrest, M. and Moore, T. 2008. Eucalyptus gunnii: A possible source of bioenergy? *Biomass and Bioenergy* 32(10): 978-980.
- 25.** Franco, C., Guiyurtlu, I. and Cabrita, I. 1998. Fluidised bed gasification of eucalyptus grown under different fertilization conditions: The 10th European Conference on Biomass for Energy and Industry, June 1998, Würzburg, Germany.
- 26.** Gasification for power generation. *Fuel* **74**, 631–653.
- 27.** Gemtos, T. A. and Tsiricoglou, Thesis. 1999. Harvesting of cotton residues for energy production. *Biomass and Bioenergy*, (16) 51-59.
- 28.** Graham, R. G. & Huffman, D. R. 1981). Gasification of wood in a commercial-scale.
- 29.** Downdraft gasifier, Symposium papers, Energy from Biomass and Wastes V, January 26-30, pp. 633-649.
- 30.** Hagström, P. 2006. Biomass potential for heat, electricity and vehicle fuel in Sweden, Doctoral dissertation, Department of Bioenergy, SLU, Acta Universitatis Agriculturae Sueciae vol. 2006:11.
- 31.** Hall, D. O. and Overend, R. P. 1987. Biomass regenerable energy. John Wiley & Sons. pp 78-203.

- 32.** Higman, C. and van der Burgt, M. 2003. Gasification. Elsevier Science (USA). 200 Wheeler Road. Burlington. Page 67-70.
- 33.** Hill, C. A. S. 2006. Wood Modification: Chemical, Thermal and other processes. Wiley Series in Renewable Resources. School of Agricultural and Forest Sciences, University of Wales, Bangor.
- 34.** Jahah, T.H. 2002. Evaluation of a downdraft wood gasifier for tea manufacturing in Sri Lanka. M. Eng.Sc. thesis. Department of Civil and Environmental Engineering. University of Melbourne.
- 35.** Jenkins, B.M. 1980. Downdraught gasification characteristics of major California residue-derived fuels, Ph.D. Thesis. Engineering, University of California. Davis, U.S.A.
- 36.** Jenkins, B.M., Baxter, L. L., Miles, T. R. & Miles, T. R. 1998. Combustion properties of biomass. Fuel Processing Technology. 1-3(15), p. 17-46.
- 37.** Kaliyan, N. and Morey, V. N. 2009. Biomass and Bioenergy, 33, 337-359.
- 38.** Kim et al. 2001. Thermal decomposition of cellulose crystallites in wood, Holzforschung 55, 521-524.
- 39.** Kitani, O. and Hall, C. W. 1989. Biomass Handbook. OPA Amsterdam B. V. pp. 142-159.

40. Klensch, S. 2001. In Higman, C. and van der Burgt, M., 2003. Gasification. Elsevier Science (USA). 200 Wheeler Road. Burlington. Page 70.
41. Larsson, S. H., Thyrel, M. et al. 2008. High quality biofuel pellet production from pre-compacted low density raw materials. *Bioresource Technology* 99(15): 7176-7182.
42. Lindley, J. and Vossoughi, M. 1989. Physical properties of biomass briquettes. *Transaction of the ASAE*. Vol. 32(2). pp 361-366.
43. Maciejewska, A., Veringa, H., Sanders, J. P. M. and Peteves, S.D., 2006. Co-firing of biomass with coal: Constraints and role of biomass pre-treatment, Luxembourg: Office for Official Publications of the European Communities, 2006 - p. 113.
44. Maryland Environmental Service (MES) Report, November 1999, ECI Cogeneration Facility, Full-Scale Poultry Litter Test Burn, Ref: Air Nova, Inc. "Maryland Environmental Service Poultry Litter Test Burn Emission Evaluation Test Program", December 1999.
45. Mermet, J. M. 2005. "Is it still possible, necessary and beneficial to perform research in ICP-atomic emission spectrometry?". *J. Anal. At. Spectrom.* 20: 11–16.
46. Milne, T. A. & Evans F. W. et al. 1998. Biomass Gasification "Tars" Their Nature, Formation and Conversion.

- 47.** Mishra, P. D. G. S. K. (1996). Biomass briquetting: technology and practices. Bangkok, Regional Wood Energy Development Programme in Asia.
- 48.** Mukhtar, S.A.K., 2002, Co-Firing of Coal and Broiler Litter (BL) Fuels for Power Generation: BL Fuel Quality and Characteristics, ASAE Paper No. 024189, Chicago, Illinois, St. Joseph, Michigan: ASABE.
- 49.** Munalula, F. and Meincken, M., 2009. Biomass and Bioenergy, 33(3): 415-420.
- 50.** Olanders, B. and Steenari, B.M. 1995. Characterization of Ashes from Wood and Straw. Biomass and Bioenergy Vol. 8, No. 2, pp. 105-115. 1995 Elsevier Science Ltd. Organization of the United Nations, Via delle Treme di Caracalla, 00100 Rome, Italy. pp 2-33.
- 51.** Ortega-Regules, A. and Romero-Cascales, I et al. 2006. A first approach towards the relationship between grape skin cell-wall composition and anthocyanin extractability. Analytica Chimica Acta 563(1-2): 26-32.
- 52.** Parikh, J., Channiwala, S. A. and Ghosal, G. K. 2007. A correlation for calculating elemental composition from proximate analysis of biomass materials. Fuel 86(12-13): 1710-1719.
- 53.** Rajvanshi, A. K. 1986. Biomass Gasification. Alternative Energy in Agriculture. D. Yogi Goswami and CRC Press. Vol. II: pgs. 83-102.
- 54.** Raveendran, K., Ganesh, A. and Khilar, K.C., 1996. Pyrolysis characteristics of biomass and biomass components. Fuel 75(8), 987-998.

- 55.** Scane, J. 1993. Ontario Institute for Studies in Education. The energy educator of Ontario, 1993. Energy Council of Canada.
- 56.** Scholz, V., Berg, W. and Kaulfuss, P. 1998. Energy balance of solid biofuels. *Journal of Agricultural Engineering*. res. 71, 263-272.
- 57.** Shaw, M. D. 2008. Feedstock and Process Variables Influencing Biomass Densification, *Agricultural and Bioresource Engineering*, Master of Science, University of Saskatchewan, Canada.
- 58.** Sims, C.H., Hassler, C.C., and Bean, T.L. 1988. Wood Densification. West Virginia University Extension Service. Publication No. 838. Available Online at: [<http://www.wvu.edu/~agexten/forestry/wood838.pdf>]
- 59.** Situation Report for the World Vitivinicultural Sector in 2005, International Organization of Vine and Wine. Available Online at [ <http://www.oiv.int/>].
- 60.** Sonnenberg, H. and Graef, M. 1998. Possibilities of the production and energetic application of farm biomass. In: Proceedings of the 10th European Conference on Biomass for Energy and Industry, June 1998, Würzburg, Germany.
- 61.** Stefánsson A., Gunnarsson I., Giroud N. 2007. New methods for the direct determination of dissolved inorganic, organic and total carbon in natural waters by Reagent-Free Ion Chromatography and inductively coupled plasma atomic emission spectrometry. *Anal. Chim. Acta* 582 (1): 69–74.



- 62.** Strehler, A. 1984. Möglichkeiten der Trocknung von Holzhackschnitzeln, Sonderdruck der Landtechnik Weihenstephan, 17 Seiten.
- 63.** Strehler, A. 1998. Necessity and chances of energy from biomass and hindrance to success. The 10th European Conference on Biomass for Energy and industry, June 1998, Würzburg, Germany.
- 64.** Strehler, A. 2000. Technologies of Wood Combustion, Ecological Engineering: (Supplement) 16, 25-40.
- 65.** TAPPI, T211 om 85. 1985. Ash in Wood and Pulp.
- 66.** Torres, L. 2007. Biomass Energy Technology. Oregon Department of Energy. Available Online at: [[www.oregon.gov/ENERGY/RENEW/Biomass/bioenergy.shtml](http://www.oregon.gov/ENERGY/RENEW/Biomass/bioenergy.shtml)]
- 67.** Tsai, W.T., Lee, M.K., Chang, Y.M. 2006. Journal of Anal. Appl. Pyrolysis 76 (2006) 230–237.
- 68.** Unger, P. W. 1994. Managing Agricultural Residues. CRC Press, Inc. pp 2-20.
- 69.** Van der Aarsen, F. G. et al. 1982. Performance of a rice-husk fluidized bed pilot plant gasifier, (1st International Product Gas Conference: Colombo). Sri Lanka, Colombo.

- 70.** Walker, C. F. J. (2nd eds.). 2006. Primary Wood Processing: Principles and Practice. University of Canterbury. Christchurch. p. 542-543. Springer. New Zealand.
- 71.** White, J. W. and McGrew, W. 1976. Urban Waste and Agricultural Wastes, 77, 291-292.
- 72.** White, L. P. and Plaskett, L. G. 1981. Biomass as Fuel, (1)1-25, 28-30. Academic Press Inc. (London) Ltd 24/28 Oval Road. London NW1 7DX.
- 73.** Wilaipon, P., 2008. Physical Characteristics of Maize Cod Briquettes under Moderate Die Pressure. Available Online at:  
[<http://www.doaj.org/doaj?func=abstract&id=266609&recNo=7&toc=1>].
- 74.** Winkler, A. J., Cook, J. A., Kliwer, W. M. and Lider, A. L. 1974. General Viticulture. Berkeley and Loss Angeles. University of California. London, England.
- 75.** Xu, R., Ferrante, L., Briens, C. and Berruti, F. 2009. Flash pyrolysis of grape residues into biofuel in a bubbling fluid bed. Journal of Analytical and Applied Pyrolysis. G Model .JAAP-2328; No of Pages 8.
- 76.** Zeng, X., Y. Ma. et al. 2007. Utilization of straw in biomass energy in China. Renewable and Sustainable Energy Reviews 5: 976-987.